



**ITT**

**Lowara**

**CEA-CA  
CEA(N)-CA(N) Series  
made of AISI 316**

Single and twin-impeller  
Centrifugal Electric Pumps equipped  
with high efficiency PLM motors

**50 Hz**

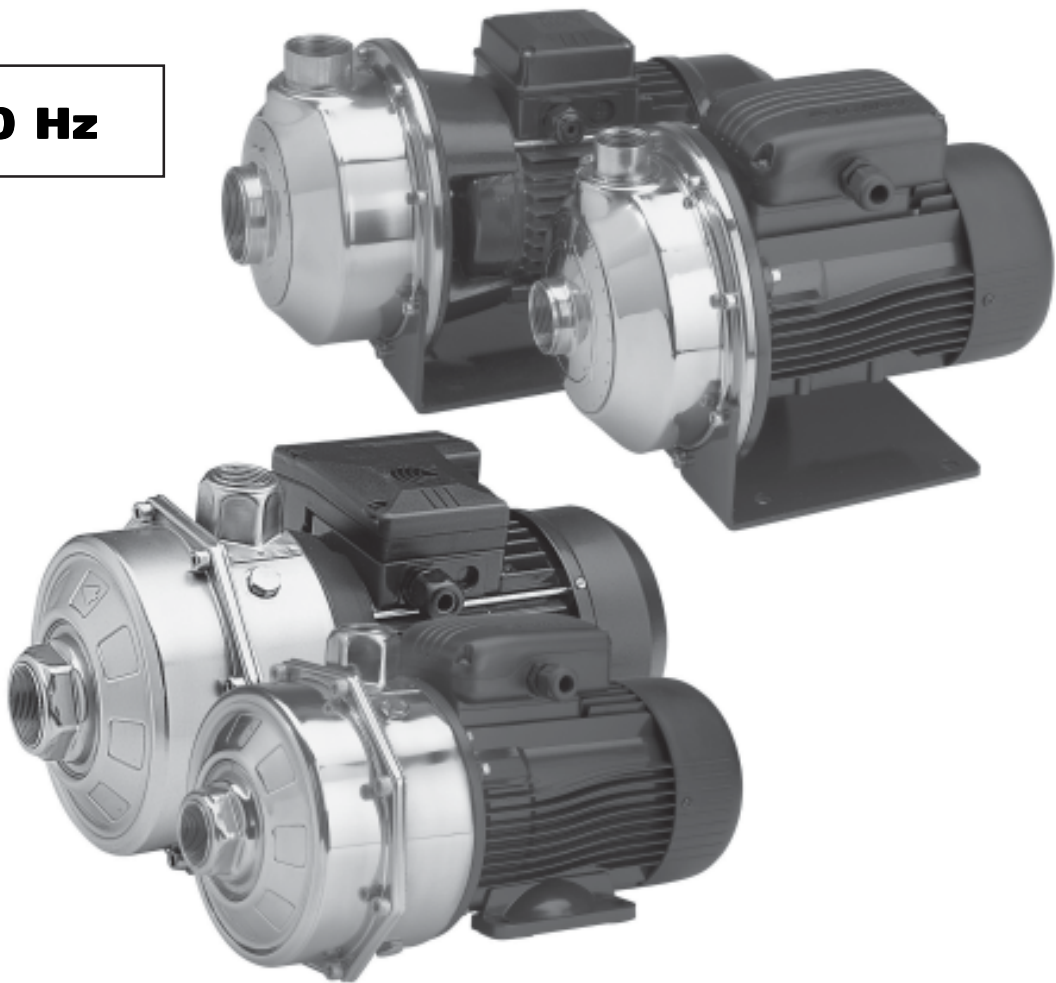

*Engineered for life*



# ITT

# Lowara

## CEA-CA - CEA(N)-CA(N) SERIES HYDRAULIC PERFORMANCE RANGE AT 50 Hz

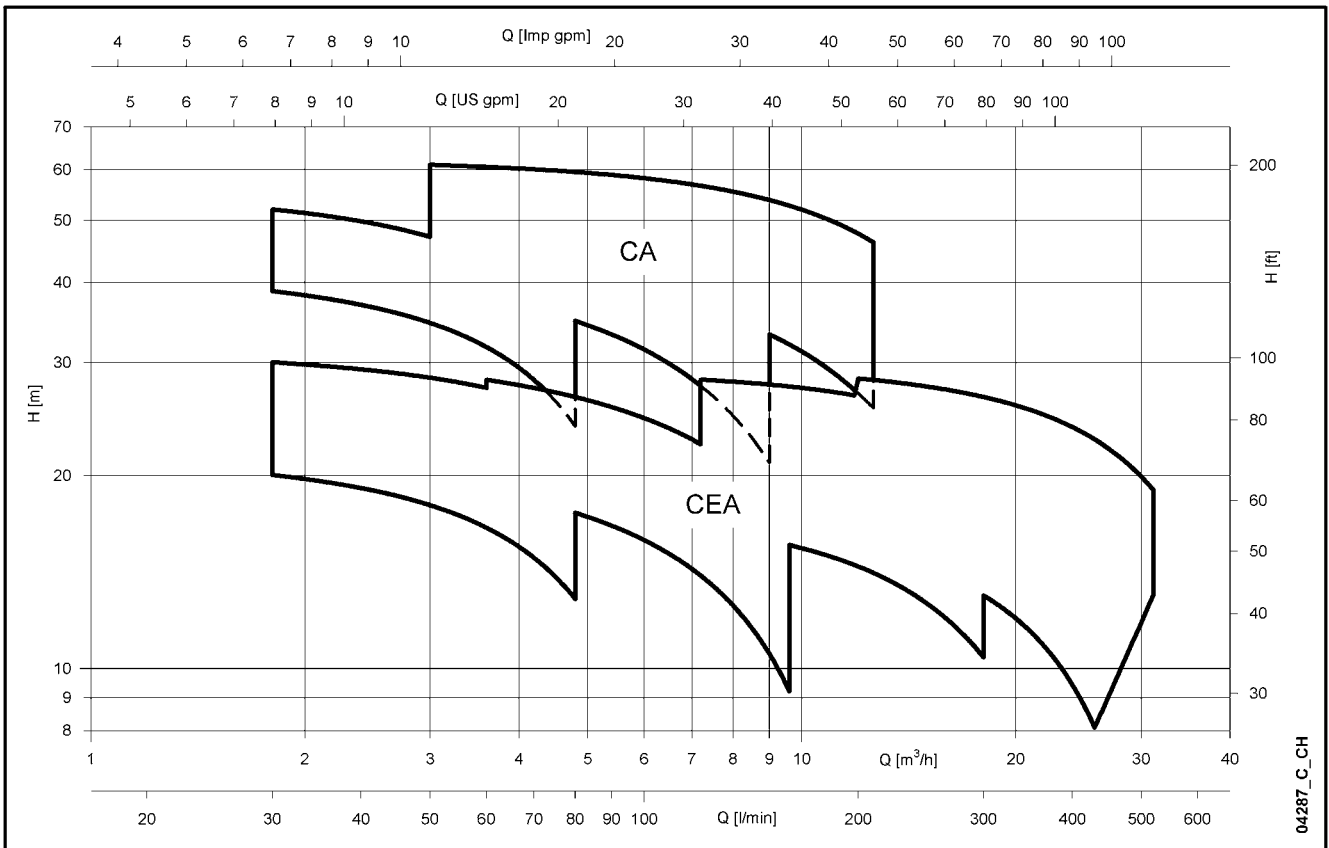

04287\_C\_CH



## CONTENTS

CEA-CEA(N) Series Specifications .....	<b>5</b>
List of Models and Table of Materials CEA-CEA(N) Series .....	<b>7</b>
Mechanical Seal CEA-CEA(N) Series .....	<b>8</b>
Hydraulic Performance Table and Electrical Data CEA-CEA(N) Series .....	<b>9</b>
Hydraulic Performance Range CEA-CEA(N) Series at 50 Hz .....	<b>10</b>
Dimensions and Weights CEA-CEA(N) Series .....	<b>15</b>
CA-CA(N) Series Specifications .....	<b>17</b>
List of Models and Table of Materials CA-CA(N) Series .....	<b>19</b>
Mechanical Seal CA-CA(N) Series .....	<b>20</b>
Hydraulic Performance Table and Electrical Data CA-CA(N) Series .....	<b>21</b>
Hydraulic Performance Range CA-CA(N) Series at 50 Hz .....	<b>22</b>
Dimensions and Weights CA-CA(N) Series .....	<b>26</b>
Technical Appendix .....	<b>27</b>



**Lowara**

## Single-Impeller Centrifugal Electric Pumps

### CEA-CEA(N) Series with high efficiency PLM motors (1)

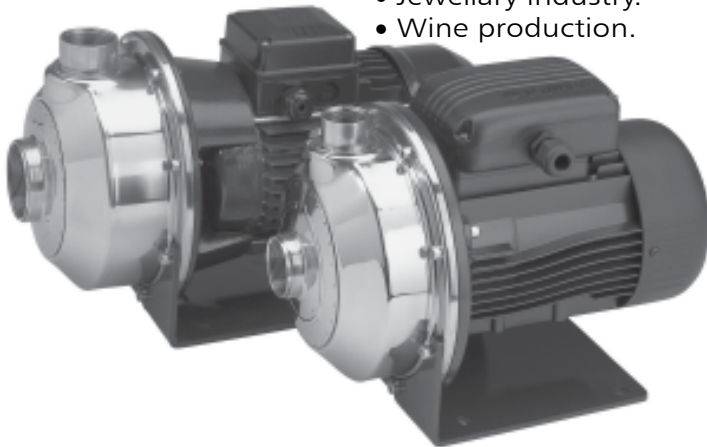

### MARKET SECTORS

CIVIL, AGRICULTURAL, INDUSTRIAL.

### APPLICATIONS

#### Version made of AISI 304

- Handling of chemically and mechanically non-aggressive water and liquids (\*).
- Water supply.
- Irrigation.
- Water circulation (cold, hot, refrigerated).

\* For moderately aggressive liquids, a version with FPM elastomers is available (CEA./.-V). For aggressive liquids, please contact our sales network.

#### “N” version made of AISI 316 (for aggressive liquids)

- Reverse osmosis (where demineralized water is used).
- Industrial washing.
- Thermal waters.
- Chlorine dispensing in swimming pools.
- Jewellery industry.
- Wine production.

the overload protection must be provided and installed by the user in the control panel.

- **Three-phase** versions: 220-240/380-415 V 50 Hz, 2 poles, the overload protection must be provided and installed by the user in the control panel.

- Condensate drain plugs in the standard version.

### CONSTRUCTION CHARACTERISTICS

- Close-coupled, single-impeller centrifugal pump featuring axial suction and radial discharge.
  - Compact construction, with pump coupled directly to motor; special motor shaft extension in common with the pump and supported by ball bearings.
  - Rotating assembly with back pull-out design, eliminating the need to disconnect the pump body from the pipe line.
  - Threaded suction and discharge ports (Rp UNI - ISO 7).
  - High performance enclosed **Impeller** made of **AISI 304** stainless steel (**AISI 316** for N version).
  - **Mechanical seal** with Ceramic/Carbon rings, NBR elastomers, (EPDM for N version) other parts are made of AISI 304 stainless steel (AISI 316 for N version). Mounting dimensions according to EN 12756 (ex DIN 24960) and ISO 3069.
  - **O-rings** made of NBR (EPDM for N version).
  - Mounting pedestal on pump body.
- ### OPTIONAL FEATURES
- Different voltages and frequencies.
  - Different material for the mechanical seal and O-rings.

### SPECIFICATIONS

#### PUMP

- **Delivery** up to 520 l/min (31 m<sup>3</sup>/h)
- **Head** up to 32 m.
- **Temperature** of pumped liquid: -10°C to +85°C standard version (\*\*).
- Maximum operating **pressure** : 8 bar (PN 8).
- Counter-clockwise rotation facing the pump from the suction port.

\*\* 110°C CEA./.-V version and N version.

#### MOTOR

- Asynchronous, squirrel cage rotor, close construction, external ventilation.
- **Protection class:** IP55.
- Class F **Insulation**.
- Performances to EN 60034-1 specifications.
- **Standard voltage:**
  - **Single-phase** versions: 220-240 V 50 Hz, 2 poles, with automatic reset overload protection up to 1,5 kW. For higher powers,

□ **The Lowara PLM surface motors have efficiency values that fall within the range normally referred to as efficiency class 1.**

(1) Available only in some models.

## CEA-CEA(N) SERIES IDENTIFICATION CODE

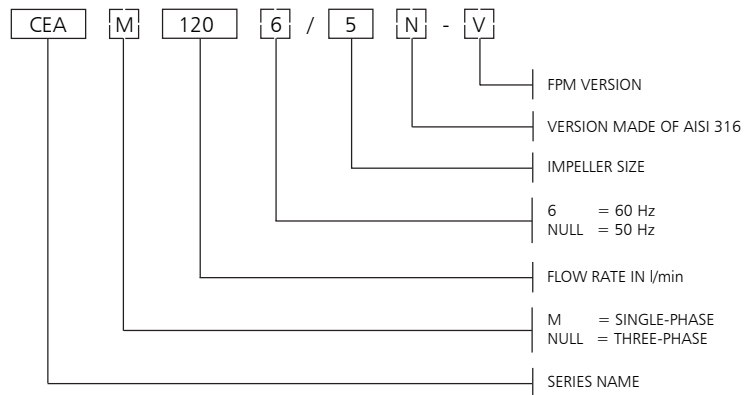

EXAMPLE : CEAM 120/5-V

CEA series electric pump, single-phase, flow rate 120 l/min  
50 Hz, Impeller size 5, FPM version.

## RATING PLATE

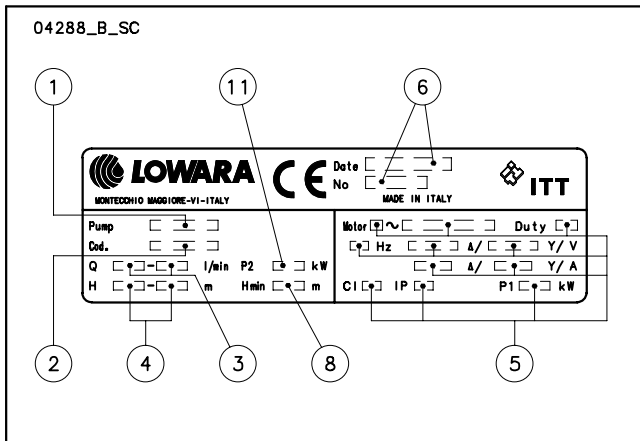

## LEGEND

- 1 - Electric pump type
- 2 - Code
- 3 - Delivery range
- 4 - Head range
- 5 - Motor characteristics
- 6 - Date of manufacturing and serial number
- 8 - Minimum head
- 11 - Rated power



# ITT

# Lowara

## CEA - CEA(N) SERIES

### LIST OF MODELS AND TABLE OF MATERIALS

04304\_C\_DS

**VERSIONS**

CEA70/3
CEA70/5
CEA80/5
CEA120/3
CEA120/5
CEA210/2
CEA210/3
CEA210/4
CEA210/5
CEA370/1
CEA370/2
CEA370/3
CEA370/5

cea-ceaN-en\_a\_mo

### CEA SERIES TABLE OF MATERIALS

REF. N.	PART	MATERIAL	REFERENCE STANDARDS	
			EUROPE	USA
1	Pump body	Stainless steel	EN 10088-1-X5CrNi18-10 (1.4301)	AISI 304
2	Impeller	Stainless steel	EN 10088-1-X5CrNi18-10 (1.4301)	AISI 304
3	Diffuser	Stainless steel	EN 10088-1-X5CrNi18-10 (1.4301)	AISI 304
4	Seal housing	Stainless steel	EN 10088-1-X5CrNi18-10 (1.4301)	AISI 304
5	Adapter	Aluminium	EN 1706-AC-AISI11Cu2 (Fe) (AC46100)	-
12	Mechanical seal	Ceramic / Carbon / NBR (standard version)		
13	Elastomers	NBR (standard version)		
16	Fill/drain plugs	Stainless steel	EN 10088-1-X5CrNiMo17-12-2 (1.4401)	AISI 316
26	Impeller lock nut	Stainless steel	EN 10088-1-X5CrNiMo17-12-2 (1.4401)	AISI 316
27	Mounting pedestal	Painted steel		
28	Pump body fastening nuts and bolts	Zinc-plated steel		
29	Shaft extension	Stainless steel	EN 10088-1-X5CrNiMo17-12-2 (1.4401)	AISI 316

### CEA(N) SERIES TABLE OF MATERIALS

cea-cea-en\_b\_tm

REF. N.	PART	MATERIAL	REFERENCE STANDARDS	
			EUROPE	USA
1	Pump body	Stainless steel	EN 10088-1-X2CrNiMo17-12-2 (1.4404)	AISI 316L
2	Impeller	Stainless steel	EN 10088-1-X2CrNiMo17-12-2 (1.4404)	AISI 316L
3	Diffuser	Stainless steel	EN 10088-1-X2CrNiMo17-12-2 (1.4404)	AISI 316L
4	Seal housing	Stainless steel	EN 10088-1-X2CrNiMo17-12-2 (1.4404)	AISI 316L
5	Adapter	Aluminium	EN 1706-AC-AISI11Cu2 (Fe) (AC46100)	-
12	Mechanical seal	Ceramic / Carbon /EPDM		
13	Elastomers	EPDM		
16	Fill/drain plugs	Stainless steel	EN 10088-1-X5CrNiMo17-12-2 (1.4401)	AISI 316
26	Impeller lock nut	Stainless steel	EN 10088-1-X5CrNiMo17-12-2 (1.4401)	AISI 316
27	Mounting pedestal	Painted steel		
28	Pump body fastening nuts and bolts	Zinc-plated		
29	Shaft extension	Stainless steel	EN 10088-1-X5CrNiMo17-12-2 (1.4401)	AISI 316

cea-ceaN-en\_a\_tm

**CEA-CEA(N) MECHANICAL SEAL, ACCORDING TO EN 12756**

Mechanical seal with mounting dimensions according to EN12756 (ex DIN 24960) and ISO 3069.

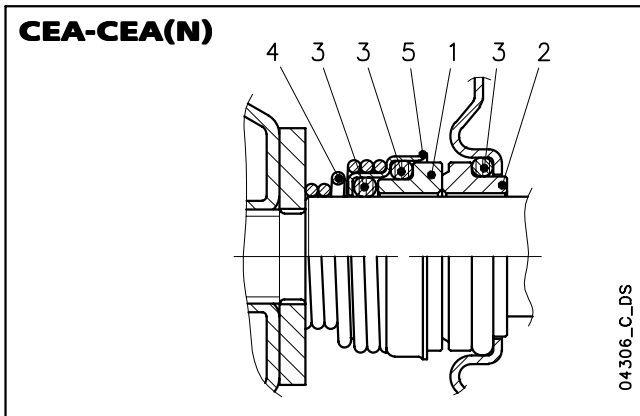
**CEA-CEA(N) LIST OF MATERIALS**

POSITION 1 - 2	POSITION 3	POSITION 4 - 5
<b>B</b> : Resin impregnated carbon	<b>P</b> : NBR	<b>F</b> : AISI 304
<b>C</b> : Special resin impregnated carbon	<b>E</b> : EPDM	<b>G</b> : AISI 316
<b>Q<sub>1</sub></b> : Silicon carbide	<b>V</b> : FPM	
<b>U<sub>3</sub></b> : Tungsten carbide		
<b>V</b> : Ceramic		

cea-ca\_ten-mec-en\_b\_tm

**CEA MECHANICAL SEALS**

TYPE	POSITION					TEMPERATURE (°C)
	1 ROTATING ASSEMBLY	2 FIXED ASSEMBLY	3 ELASTOMERS	4 SPRINGS	5 OTHER COMPONENTS	
<b>STANDARD MECHANICAL SEAL</b>						
VBPGF	V	B	P	G	F	-10 +85
<b>OTHER TYPES OF MECHANICAL SEAL</b>						
VBEGG	V	B	E	G	G	-10 +110
VCEGG	V	C	E	G	G	-10 +110
Q <sub>1</sub> Q <sub>1</sub> EGG	Q <sub>1</sub>	Q <sub>1</sub>	E	G	G	-10 +110
U <sub>3</sub> CEGG	U <sub>3</sub>	C	E	G	G	-10 +110
U <sub>3</sub> U <sub>3</sub> EGG	U <sub>3</sub>	U <sub>3</sub>	E	G	G	-10 +110
VBVGG	V	B	V	G	G	-10 +110
VCVGG	V	C	V	G	G	-10 +110
Q <sub>1</sub> Q <sub>1</sub> VGG	Q <sub>1</sub>	Q <sub>1</sub>	V	G	G	-10 +110
U <sub>3</sub> CVGG	U <sub>3</sub>	C	V	G	G	-10 +110
U <sub>3</sub> U <sub>3</sub> VGG	U <sub>3</sub>	U <sub>3</sub>	V	G	G	-10 +110

cea\_tipi-ten-mec\_b\_tc

**CEA(N) MECHANICAL SEALS**

TYPE	POSITION					TEMPERATURE (°C)
	1 ROTATING ASSEMBLY	2 FIXED ASSEMBLY	3 ELASTOMERS	4 SPRINGS	5 OTHER COMPONENTS	
<b>STANDARD MECHANICAL SEAL</b>						
VBEGG	V	B	E	G	G	-10 +110
<b>OTHER TYPES OF MECHANICAL SEAL</b>						
VCEGG	V	C	E	G	G	-10 +110
Q <sub>1</sub> Q <sub>1</sub> EGG	Q <sub>1</sub>	Q <sub>1</sub>	E	G	G	-10 +110
VCVGG	V	C	V	G	G	-10 +110
Q <sub>1</sub> Q <sub>1</sub> VGG	Q <sub>1</sub>	Q <sub>1</sub>	V	G	G	-10 +110

cean-can\_tipi-ten-mec-en\_b\_tc

**CEA-CEA(N) SERIES  
HYDRAULIC PERFORMANCE TABLE AT 50 Hz**

PUMP TYPE	RATED POWER		Q = DELIVERY																		
			l/min	0	30	40	60	80	100	120	140	160	180	200	250	300	350	400	430	480	520
	kW	HP	m <sup>3</sup> /h	0	1,8	2,4	3,6	4,8	6	7,2	8,4	9,6	10,8	12	15	18	21	24	26	29	31
H = TOTAL HEAD METRES COLUMN OF WATER																					
CEA(M) 70/3	0,37	0,5	22	20,1	19,1	16,6	12,8														
CEA(M) 70/5	0,55	0,75	31,1	28,8	27,7	24,7	20,2														
CEA(M) 80/5	0,75	1	32	30	29,3	27,4	24,7	21													
CEA(M) 120/3	0,55	0,75	22,4			18,9	17,5	15,9	14	11,8	9,2										
CEA(M) 120/5	0,9	1,2	31,8			28,2	26,5	24,6	22,4	20	17,3										
CEA(M) 210/2	0,75	1	17,7						16,5	16,1	15,6	15	14,4	12,6	10,4						
CEA(M) 210/3	1,1	1,5	20,8						19,7	19,3	19	18,5	18	16,5	14,4						
CEA(M) 210/4	1,5	2	25,5						24,8	24,5	24	23,6	23	21,3	19						
CEA(M) 210/5	1,85	2,5	29						28,2	27,9	27,5	27,1	26,6	25,1	23,1						
CEA(M) 370/1	1,1	1,5	16,3									15,5	15,2	14,3	13	11,4	9,4	8,1			
CEA(M) 370/2	1,5	2	20,4										19,1	18,3	17,2	15,8	14,1	13	10,8		
CEA(M) 370/3	1,85	2,5	24,4										22,9	22,1	21,1	19,8	18,2	17,1	15	13	
CEA370/5	3	4	30,3										28,3	27,5	26,5	25,3	23,8	22,8	21	19,0	

cea-2p50-en\_d\_th

**CEA-CEA(N) SERIES  
ELECTRICAL DATA AT 50 Hz**

PUMP TYPE SINGLE-PHASE	INPUT POWER*	INPUT CURRENT*	CAPACITOR
	kW	220-240 V A	μF / 450 V
CEAM 70/3	0,60	2,72	14
CEAM 70/5	0,97	4,55	16
CEAM 80/5	1,07	4,87	20
CEAM 120/3	0,91	4,33	16
CEAM 120/5	1,39	6,24	25
CEAM 210/2	1,13	5,10	20
CEAM 210/3	1,48	6,68	30
CEAM 210/4	1,91	8,60	40
CEAM 210/5**	2,24	10,2	70
CEAM 370/1	1,49	6,75	30
CEAM 370/2	2,05	9,26	40
CEAM 370/3**	2,45	11,1	70

PUMP TYPE THREE-PHASE	INPUT POWER*	INPUT CURRENT*	INPUT CURRENT*
	kW	220-240 V A	380-415 V A
CEA 70/3	0,61	2,51	1,45
CEA 70/5	0,88	2,86	1,65
CEA 80/5	1,06	3,65	2,11
CEA 120/3	0,82	2,74	1,58
CEA 120/5	1,32	4,52	2,61
CEA 210/2	1,12	3,76	2,17
CEA 210/3	1,43	4,68	2,70
CEA 210/4	1,84	6,04	3,49
CEA 210/5	2,28	8,35	4,82
CEA 370/1	1,44	4,71	2,72
CEA 370/2	1,99	6,32	3,65
CEA 370/3	2,47	8,63	4,98
CEA 370/5**	3,32	10,3	5,96

\*Maximum value in specified range.

\*\* Electric pumps equipped with PLM motors.

cea-2p50-en\_d\_te



# ITT

# Lowara

## CEA-CEA(N) SERIES HYDRAULIC PERFORMANCE RANGE AT 50 Hz

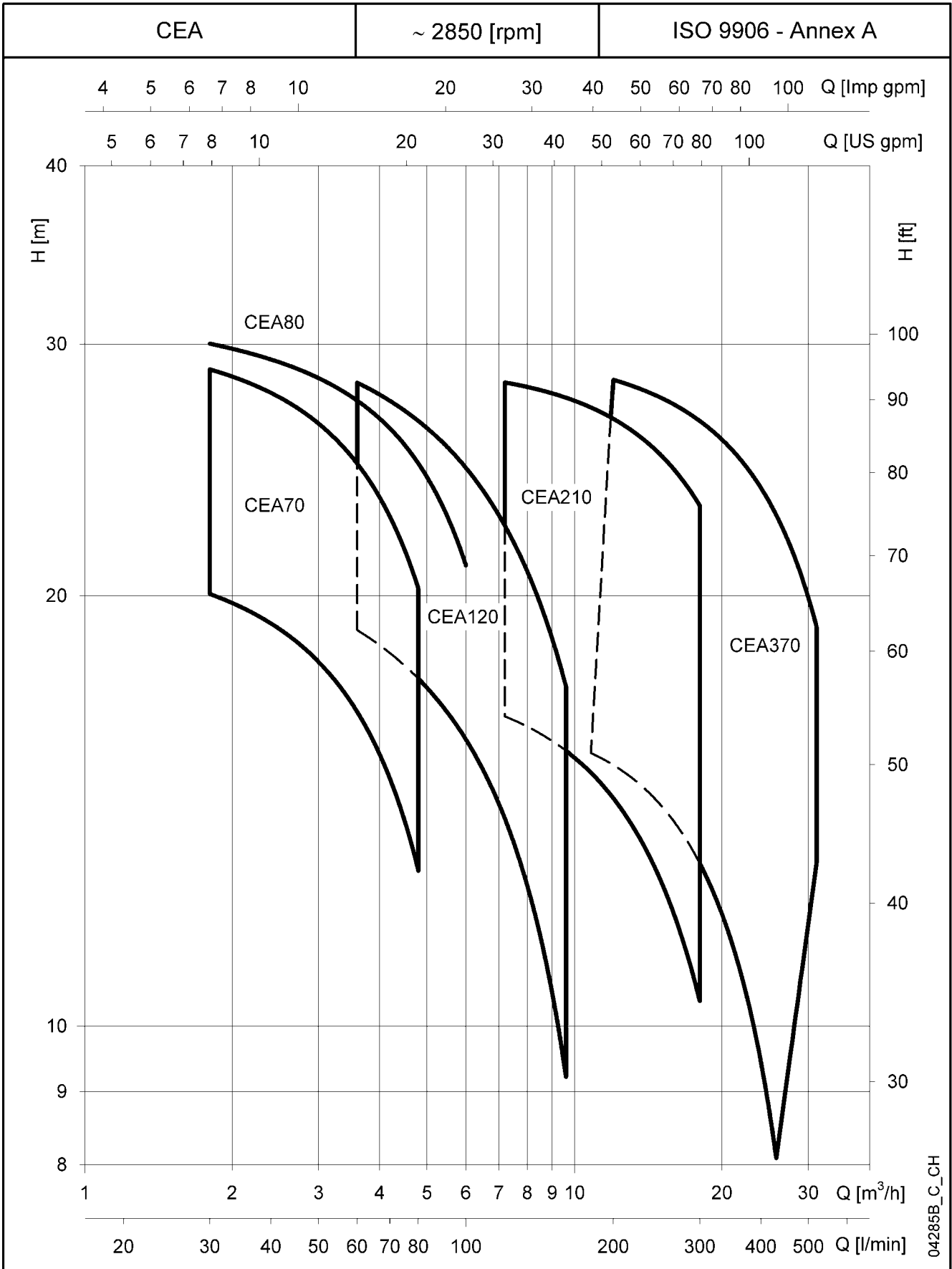

04285B\_C\_CH



# ITT

# Lowara

## CEA70-CEA80 SERIES OPERATING CHARACTERISTICS AT 50 Hz

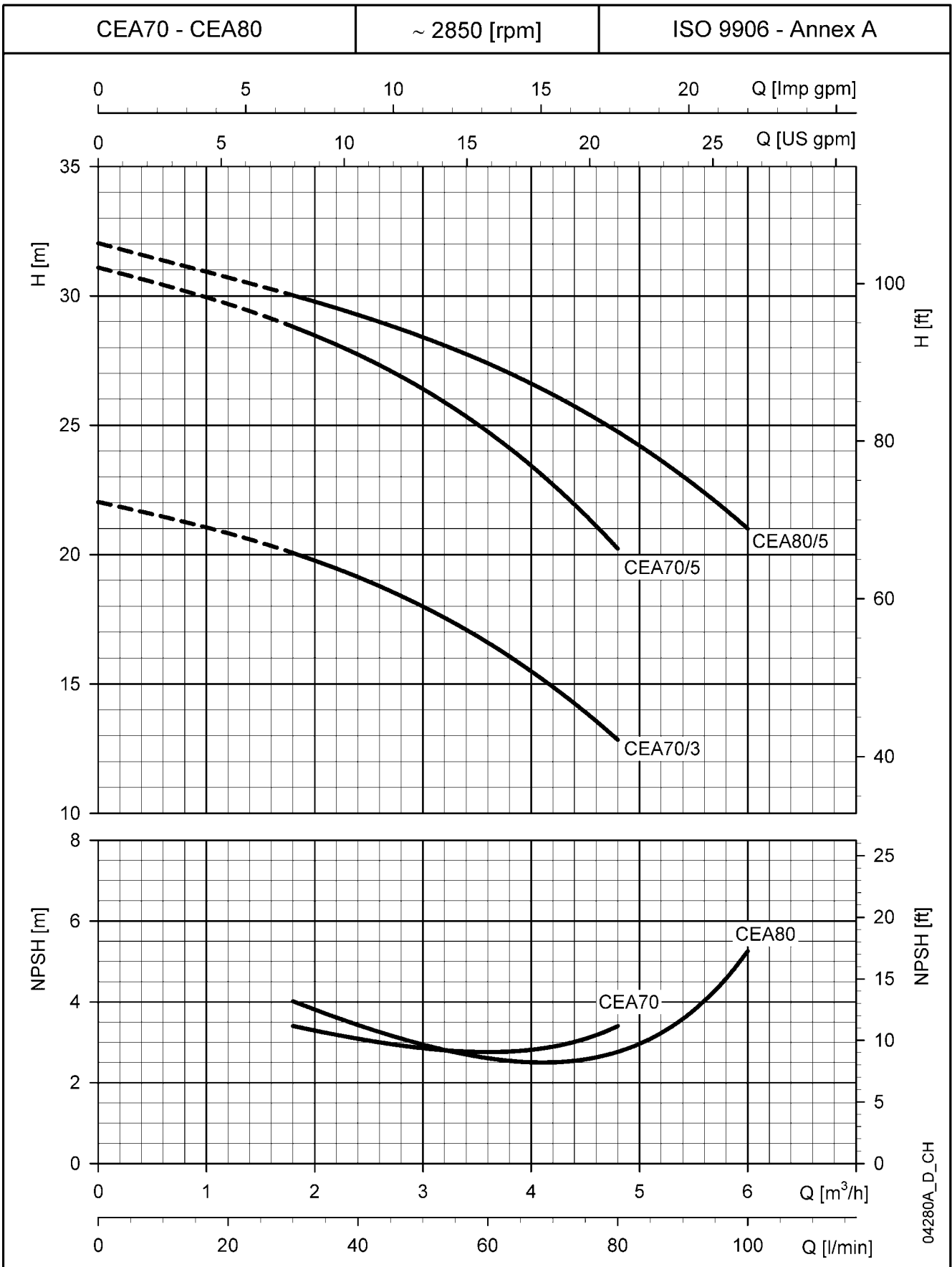

04280A\_D\_CH

These performances are valid for liquids with density  $\rho = 1.0 \text{ Kg/dm}^3$  and kinematic viscosity  $\nu = 1 \text{ mm}^2/\text{sec}$ .



# ITT

# Lowara

## CEA120 SERIES OPERATING CHARACTERISTICS AT 50 Hz

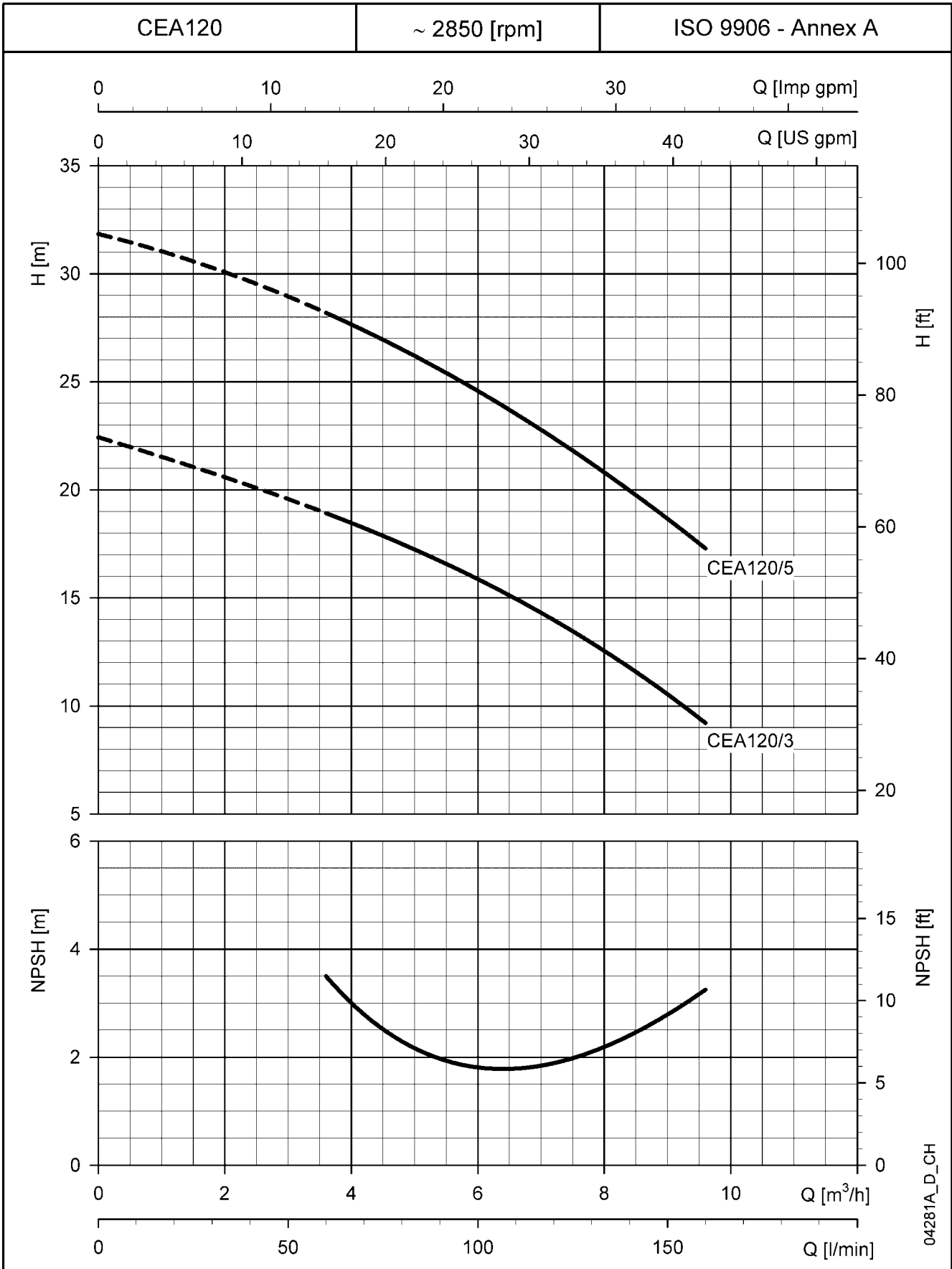

These performances are valid for liquids with density  $\rho = 1.0 \text{ Kg/dm}^3$  and kinematic viscosity  $\nu = 1 \text{ mm}^2/\text{sec}$ .



# ITT

# Lowara

## CEA210 SERIES OPERATING CHARACTERISTICS AT 50 Hz

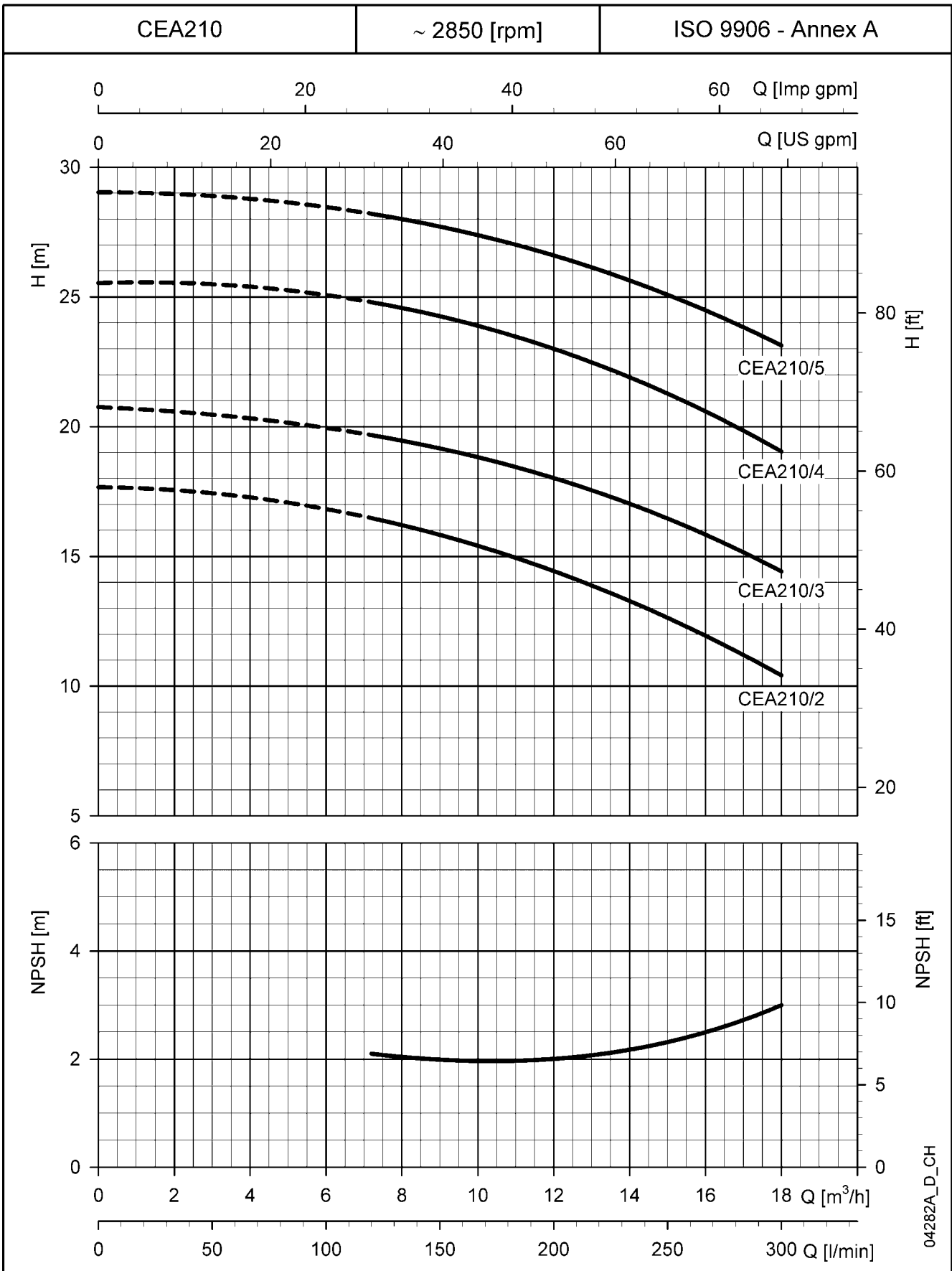

04282A\_D\_CH

These performances are valid for liquids with density  $\rho = 1.0 \text{ Kg/dm}^3$  and kinematic viscosity  $\nu = 1 \text{ mm}^2/\text{sec}$ .



# ITT

# Lowara

## CEA370 SERIES OPERATING CHARACTERISTICS AT 50 Hz

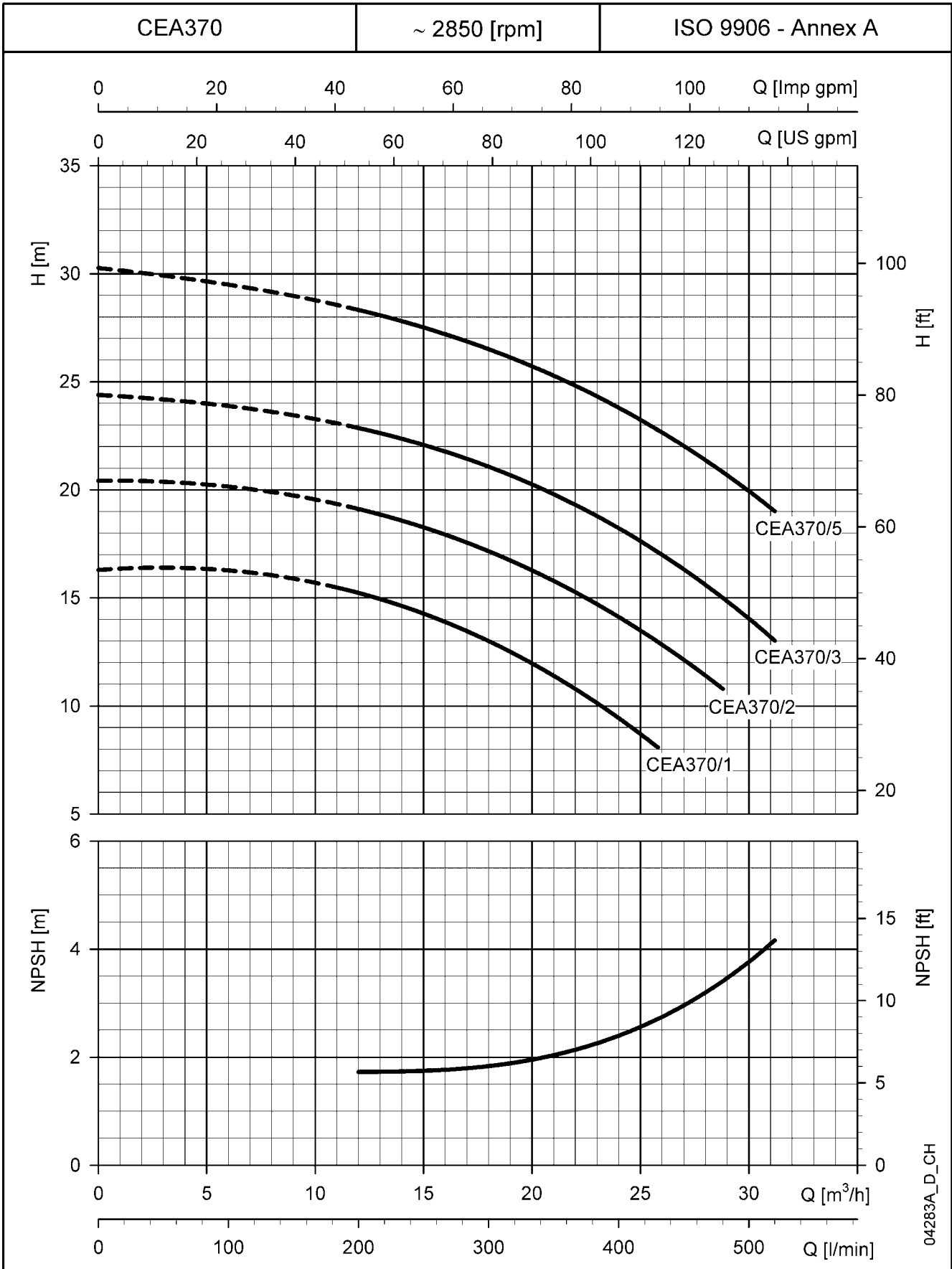

04283A\_D\_CH

These performances are valid for liquids with density  $\rho = 1.0 \text{ Kg/dm}^3$  and kinematic viscosity  $\nu = 1 \text{ mm}^2/\text{sec}$ .



# ITT

# Lowara

## CEA-CEA(N) SERIES DIMENSIONS AND WEIGHTS

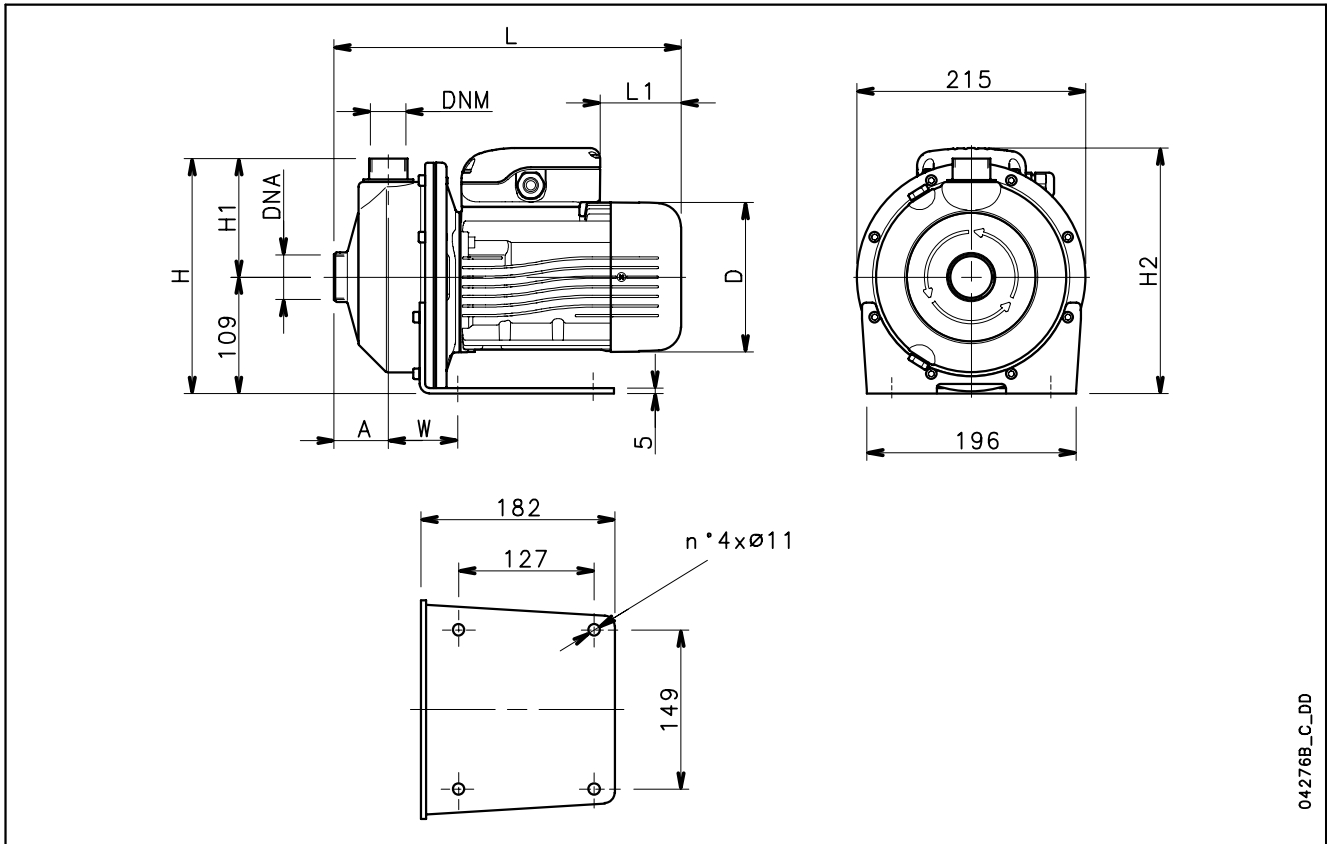

04276B\_C\_DD

PUMP TYPE	DIMENSIONS (mm)								DNA	DNM	WEIGHT kg
	A	D	H	H1	H2	L	L1	W			
CEAM 70/3	51	120	220	111	220	311	62	65	Rp 1¼	Rp 1	9,7
CEAM 70/5	51	140	220	111	230	325	76	65	Rp 1¼	Rp 1	11,6
CEAM 80/5	51	140	220	111	230	325	76	65	Rp 1¼	Rp 1	12,5
CEAM 120/3	51	140	220	111	230	325	76	65	Rp 1¼	Rp 1	11,5
CEAM 120/5	51	140	220	111	239	325	31	65	Rp 1¼	Rp 1	13
CEAM 210/2	54	140	222	113	230	339	76	76	Rp 1½	Rp 1¼	13
CEAM 210/3	54	156	222	113	246	385	69	76	Rp 1½	Rp 1¼	14,5
CEAM 210/4	54	156	222	113	246	385	69	76	Rp 1½	Rp 1¼	16,1
CEAM 210/5*	54	174	222	113	243	429	84	76	Rp 1½	Rp 1¼	17
CEAM 370/1	54	156	222	113	246	385	69	76	Rp 2	Rp 1¼	14
CEAM 370/2	54	156	222	113	246	385	69	76	Rp 2	Rp 1¼	16,1
CEAM 370/3*	54	174	222	113	243	429	84	76	Rp 2	Rp 1¼	20
CEA 70/3	51	120	220	111	220	311	62	65	Rp 1¼	Rp 1	9,7
CEA 70/5	51	140	220	111	230	325	76	65	Rp 1¼	Rp 1	11,6
CEA 80/5	51	140	220	111	230	325	76	65	Rp 1¼	Rp 1	12,5
CEA 120/3	51	140	220	111	230	325	76	65	Rp 1¼	Rp 1	11,5
CEA 120/5	51	140	220	111	230	325	76	65	Rp 1¼	Rp 1	13
CEA 210/2	54	140	222	113	230	339	76	76	Rp 1½	Rp 1¼	13
CEA 210/3	54	156	222	113	238	385	114	76	Rp 1½	Rp 1¼	14,5
CEA 210/4	54	156	222	113	238	385	114	76	Rp 1½	Rp 1¼	16,1
CEA 210/5	54	156	222	113	238	385	114	76	Rp 1½	Rp 1¼	14,4
CEA 370/1	54	156	222	113	238	285	114	76	Rp 2	Rp 1¼	14
CEA 370/2	54	156	222	113	238	385	114	76	Rp 2	Rp 1¼	16,1
CEA 370/3	54	156	222	113	238	385	114	76	Rp 2	Rp 1¼	17,7
CEA 370/5*	54	174	222	113	243	429	172	76	Rp 2	Rp 1¼	21

\* Electric pumps equipped with PLM motors.



**Lowara**

## Twin-Impeller Centrifugal Electric Pumps

### CA-CA(N) Series with high efficiency PLM motors (1)

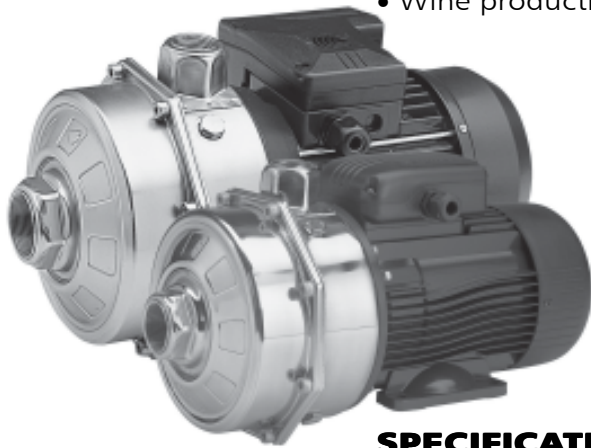

### MARKET SECTORS

CIVIL, AGRICULTURAL, INDUSTRIAL.

### APPLICATIONS

#### Version made of AISI 304

- Handling of chemically and mechanically non-aggressive water and liquids (\*).
- Water supply.
- Irrigation.
- Water circulation (cold, hot, refrigerated).

\* For moderately aggressive liquids, a version with FPM elastomers is available (CA../.-V). For aggressive liquids, please contact our sales network.

#### “N” version made of AISI 316 (for aggressive liquids)

- Reverse osmosis (where demineralized water is used).
- Industrial washing.
- Thermal waters.
- Chlorine dispensing in swimming pools.
- Jewellery industry.
- Wine production.

the overload protection must be provided and installed by the user in the control panel.

- **Three-phase** versions: 220-240/380-415 V 50 Hz, 2 poles, the overload protection must be provided and installed by the user in the control panel.

- Condensate drain plugs in the standard version.

### CONSTRUCTION CHARACTERISTICS

- Close-coupled, single-impeller centrifugal pump featuring axial suction and radial discharge.
- Compact construction, with pump coupled directly to motor; special motor shaft extension in common with the pump and supported by ball bearings.
- Threaded suction and discharge ports (Rp UNI - ISO 7).
- High performance enclosed **Impeller** made of **AISI 304** stainless steel (**AISI 316** for N version).
- **Mechanical seal** with Ceramic/Carbon rings, NBR elastomers, (EPDM for N version) other parts are made of AISI 304 stainless steel (AISI 316 for N version). Mounting dimensions according to EN 12756 (ex DIN 24960) and ISO 3069.
- **O-rings** made of NBR (EPDM for N version).
- Mounting pedestal on motor.

### SPECIFICATIONS PUMP

- **Delivery** up to 210 l/min (12,5 m<sup>3</sup>/h).
- **Head** fino a 62 m.
- **Temperature** of pumped liquid: -10°C to +85°C standard version (\*\*).
- Maximum operating **pressure** : 8 bar (PN 8).
- Counter-clockwise rotation facing the pump from the suction port.

\*\* 110°C CA../.-V version and N version.

### MOTOR

- Asynchronous, squirrel cage rotor, close construction, external ventilation.
- **Protection class:** IP55.
- Class F **Insulation**.
- Performances to EN 60034-1 specifications.
- **Standard voltage:**
  - **Single-phase** versions: 220-240 V 50 Hz, 2 poles, with automatic reset overload protection up to 1,5 kW. For higher powers,

□ **The Lowara PLM surface motors have efficiency values that fall within the range normally referred to as efficiency class 1.**

(1) Available only in some models.

### OPTIONAL FEATURES

- Different voltages and frequencies.
- Different material for the mechanical seal and O-rings.

## CA-CA(N) SERIES IDENTIFICATION CODE

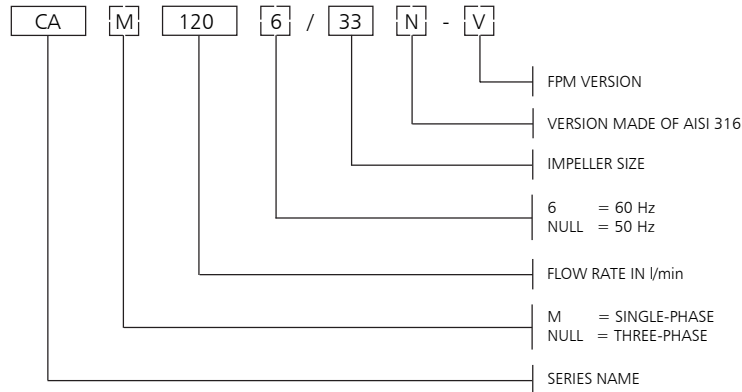

EXAMPLE : CAM 120/33-V

CA series electric pump, single-phase, flow rate 120 l/min  
50 Hz, Impeller size 33, FPM version.

## RATING PLATE

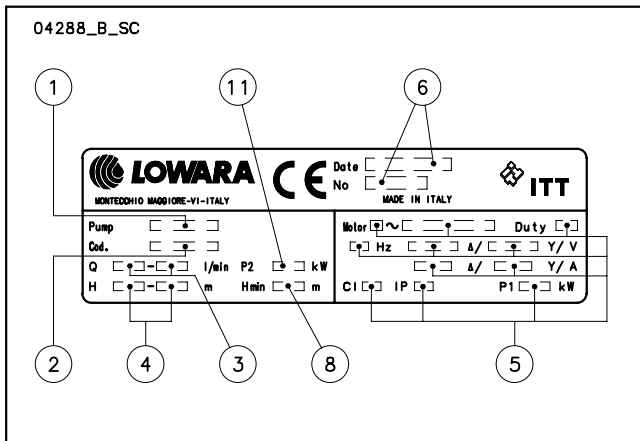

## LEGEND

- 1 - Electric pump type
- 2 - Code
- 3 - Delivery range
- 4 - Head range
- 5 - Motor characteristics
- 6 - Date of manufacturing and serial number
- 8 - Minimum head
- 11 - Rated power

**CA - CA(N) SERIES  
LIST OF MODELS AND TABLE OF MATERIALS**

02179\_B\_DS

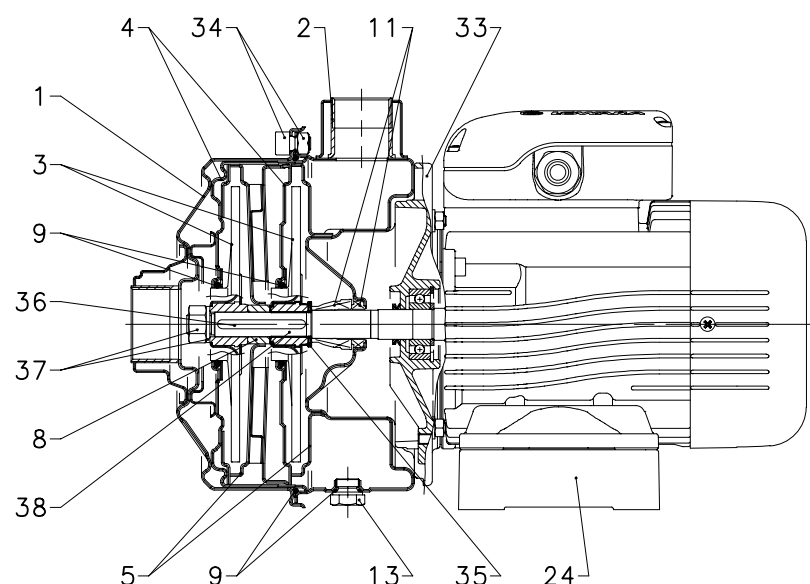

VERSIONS	
CA70/33	
CA70/34	
CA70/45	
CA120/33	
CA120/35	
CA120/55	
CA200/33	
CA200/35	
CA200/55	

ca-caN-en\_a\_mo

**CA SERIES TABLE OF MATERIALS**

REF. N.	PART	MATERIAL	REFERENCE STANDARDS	
			EUROPE	USA
1	Suction flange	Stainless steel	EN 10088-1-X5CrNi18-10 (1.4301)	AISI 304
2	Pump body	Stainless steel	EN 10088-1-X5CrNi18-10 (1.4301)	AISI 304
3	Impeller	Stainless steel	EN 10088-1-X5CrNi18-10 (1.4301)	AISI 304
4	Diffuser cover	Stainless steel	EN 10088-1-X5CrNi18-10 (1.4301)	AISI 304
5	Diffuser cover	Stainless steel	EN 10088-1-X5CrNi18-10 (1.4301)	AISI 304
8	Impeller spacer	Stainless steel	EN 10088-1-X5CrNi18-10 (1.4301)	AISI 304
9	Elastomers	NBR (standard version)		
11	Mechanical seal	Ceramic / Carbon / NBR (standard version)		
13	Fill/drain plugs	Stainless steel	EN 10088-1-X5CrNiMo17-12-2 (1.4401)	AISI 316
24	Mounting pedestal	Aluminium	EN 1706-AC-AISI11Cu2 (Fe) (AC46100)	-
33	Adapter	Aluminium	EN 1706-AC-AISI11Cu2 (Fe) (AC46100)	-
34	Pump body fastening nuts and bolts	Zinc-plated steel		
35	Impeller shoulder washer	Stainless steel	EN 10088-1-X5CrNi18-10 (1.4301)	AISI 304
36	Key	Stainless steel	EN 10088-1-X5CrNiMo17-12-2 (1.4401)	AISI 316
37	Impeller lock nut and washer	Stainless steel	EN 10088-1-X5CrNi18-10 (1.4301)	AISI 304
38	Shaft extension	Stainless steel	EN 10088-1-X5CrNiMo17-12-2 (1.4401)	AISI 316

**CA(N) SERIES TABLE OF MATERIALS**

ca-ca-en\_b\_tm

REF. N.	PART	MATERIAL	REFERENCE STANDARDS	
			EUROPE	USA
1	Suction flange	Stainless steel	EN 10088-1-X2CrNiMo17-12-2 (1.4404)	AISI 316L
2	Pump body	Stainless steel	EN 10088-1-X2CrNiMo17-12-2 (1.4404)	AISI 316L
3	Impeller	Stainless steel	EN 10088-1-X2CrNiMo17-12-2 (1.4404)	AISI 316L
4	Diffuser cover	Stainless steel	EN 10088-1-X2CrNiMo17-12-2 (1.4404)	AISI 316L
5	Diffuser	Stainless steel	EN 10088-1-X2CrNiMo17-12-2 (1.4404)	AISI 316L
8	Impeller spacer	Stainless steel	EN 10088-1-X5CrNiMo17-12-2 (1.4401)	AISI 316
9	Elastomers	EPDM (standard version)		
11	Mechanical seal	Ceramic / Carbon / EPDM (standard version)		
13	Fill/drain plugs	Stainless steel	EN 10088-1-X5CrNiMo17-12-2 (1.4401)	AISI 316
24	Mounting pedestal	Aluminium	EN 1706-AC-AISI11Cu2 (Fe) (AC46100)	-
33	Adapter	Aluminium	EN 1706-AC-AISI11Cu2 (Fe) (AC46100)	-
34	Pump body fastening nuts and bolts	Zinc-plated steel		
35	Impeller shoulder washer	Stainless steel	EN 10088-1-X2CrNiMo17-12-2 (1.4404)	AISI 316L
36	Key	Stainless steel	EN 10088-1-X5CrNiMo17-12-2 (1.4401)	AISI 316
37	Impeller lock nut and washer	Stainless steel	EN 10088-1-X5CrNiMo17-12-2 (1.4401)	AISI 316
38	Shaft extension	Stainless steel	EN 10088-1-X5CrNiMo17-12-2 (1.4401)	AISI 316

ca-caN-en\_a\_tm

## CA-CA(N) MECHANICAL SEAL, ACCORDING TO EN 12756

Mechanical seal with mounting dimensions according to EN12756 (ex DIN 24960) and ISO 3069.

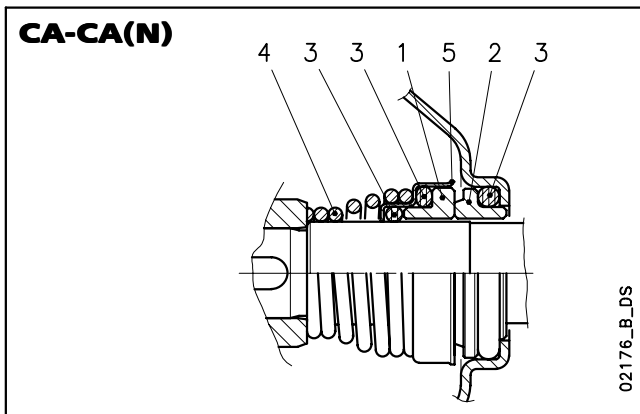

### CA-CA(N) LIST OF MATERIALS

POSITION 1 - 2	POSITION 3	POSITION 4 - 5
<b>B</b> : Resin impregnated carbon	<b>P</b> : NBR	<b>F</b> : AISI 304
<b>C</b> : Special resin impregnated carbon	<b>E</b> : EPDM	<b>G</b> : AISI 316
<b>Q<sub>1</sub></b> : Silicon carbide	<b>V</b> : FPM	
<b>U<sub>3</sub></b> : Tungsten carbide		
<b>V</b> : Ceramic		

cea-ca\_ten-mec-en\_b\_tm

### CA MECHANICAL SEALS

TYPE	POSITION					TEMPERATURE (°C)
	1 ROTATING ASSEMBLY	2 FIXED ASSEMBLY	3 ELASTOMERS	4 SPRINGS	5 OTHER COMPONENTS	
<b>STANDARD MECHANICAL SEAL</b>						
VBPGF	V	B	P	G	F	-10 +85
<b>OTHER TYPES OF MECHANICAL SEAL</b>						
VBEGF	V	B	E	G	F	-10 +110
VCEGG	V	C	E	G	G	-10 +110
Q <sub>1</sub> Q <sub>1</sub> EGF	Q <sub>1</sub>	Q <sub>1</sub>	E	G	F	-10 +110
U <sub>3</sub> BEGF	U <sub>3</sub>	B	E	G	F	-10 +110
U <sub>3</sub> CEGF	U <sub>3</sub>	C	E	G	F	-10 +110
U <sub>3</sub> U <sub>3</sub> EGF	U <sub>3</sub>	U <sub>3</sub>	E	G	F	-10 +110
VBVGF	V	B	V	G	F	-10 +110
VCVGF	V	C	V	G	F	-10 +110
Q <sub>1</sub> Q <sub>1</sub> VGF	Q <sub>1</sub>	Q <sub>1</sub>	V	G	F	-10 +110
U <sub>3</sub> CVGF	U <sub>3</sub>	C	V	G	F	-10 +110
U <sub>3</sub> U <sub>3</sub> VGF	U <sub>3</sub>	U <sub>3</sub>	V	G	F	-10 +110

ca\_tipi-ten-mec-en\_b\_tc

### CA(N) MECHANICAL SEALS

TYPE	POSITION					TEMPERATURE (°C)
	1 ROTATING ASSEMBLY	2 FIXED ASSEMBLY	3 ELASTOMERS	4 SPRINGS	5 OTHER COMPONENTS	
<b>STANDARD MECHANICAL SEAL</b>						
VBEGG	V	B	E	G	G	-10 +110
<b>OTHER TYPES OF MECHANICAL SEAL</b>						
VCEGG	V	C	E	G	G	-10 +110
Q <sub>1</sub> Q <sub>1</sub> EGG	Q <sub>1</sub>	Q <sub>1</sub>	E	G	G	-10 +110
VCVGG	V	C	V	G	G	-10 +110
Q <sub>1</sub> Q <sub>1</sub> VGG	Q <sub>1</sub>	Q <sub>1</sub>	V	G	G	-10 +110

cean-can\_tipi-ten-mec-en\_b\_tc



# ITT

# Lowara

## CA-CA(N) SERIES HYDRAULIC PERFORMANCE TABLE AT 50 Hz

PUMP TYPE	RATED POWER		Q = DELIVERY												
			l/min	0	30	40	50	60	70	80	100	120	150	180	210
	kW	HP	m <sup>3</sup> /h	0	1,8	2,4	3	3,6	4,2	4,8	6	7,2	9	10,8	12,6
H = TOTAL HEAD METRES COLUMN OF WATER															
CA(M) 70/33	0,75	1	42,9	38,8	36,9	34,6	31,7	28,2	23,9						
CA(M) 70/34	0,9	1,2	48,8	45,1	43,2	40,7	37,7	34,0	29,5						
CA(M) 70/45	1,1	1,5	56,2	52,0	49,8	47,1	43,9	39,9	35,3						
CA(M) 120/33	1,1	1,5	44,3			39,1	37,8	36,4	34,8	31,4	27,6	21,0			
CA(M) 120/35	1,5	2	54,0			49,4	48,1	46,6	44,9	41,2	36,8	29,3			
CA(M) 120/55	2,2	3	63,8			59,6	58,2	56,6	54,8	50,6	45,7	37,1			
CA(M) 200/33	1,85	2,5	43,2			41,8	41,2	40,6	39,9	38,3	36,4	33,2	29,5	25,5	
CA(M) 200/35	2,2	3	53,5			52,4	51,9	51,4	50,7	49,2	47,5	44,3	40,6	36,5	
CA 200/55	3	4	62,6			61,0	60,6	60,1	59,5	58,2	56,6	53,8	50,4	46,2	

ca-2p50-en\_d\_th

## CA-CA(N) SERIES ELECTRICAL DATA AT 50 Hz

PUMP TYPE SINGLE-PHASE	INPUT POWER*	INPUT CURRENT*	CAPACITOR
	kW	220-240 V A	μF / 450 V
CAM 70/33	1,15	5,16	20
CAM 70/34	1,39	6,22	25
CAM 70/45	1,76	7,92	30
CAM 120/33	1,67	7,53	30
CAM 120/35	2,18	9,87	40
CAM 120/55**	2,54	11,5	70
CAM 200/33**	2,29	10,4	70
CAM 200/35**	2,94	12,6	70
-	-	-	-

PUMP TYPE THREE-PHASE	INPUT POWER*	INPUT CURRENT*	INPUT CURRENT*
	kW	220-240 V A	380-415 V A
CA 70/33	1,14	3,78	2,18
CA 70/34	1,32	4,52	2,61
CA 70/45	1,71	5,23	3,02
CA 120/33	1,62	5,06	2,92
CA 120/35	2,13	6,58	3,80
CA 120/55	2,62	8,89	5,13
CA 200/33	2,34	8,44	4,87
CA 200/35**	3,02	9,07	5,24
CA 200/55**	3,58	10,9	6,30

ca-2p50-en\_c\_te

\*Maximum values within operating range.

\*\* Electric pumps equipped with PLM motors.



# ITT

# Lowara

## CA-CA(N) SERIES HYDRAULIC PERFORMANCE RANGE AT 50 Hz

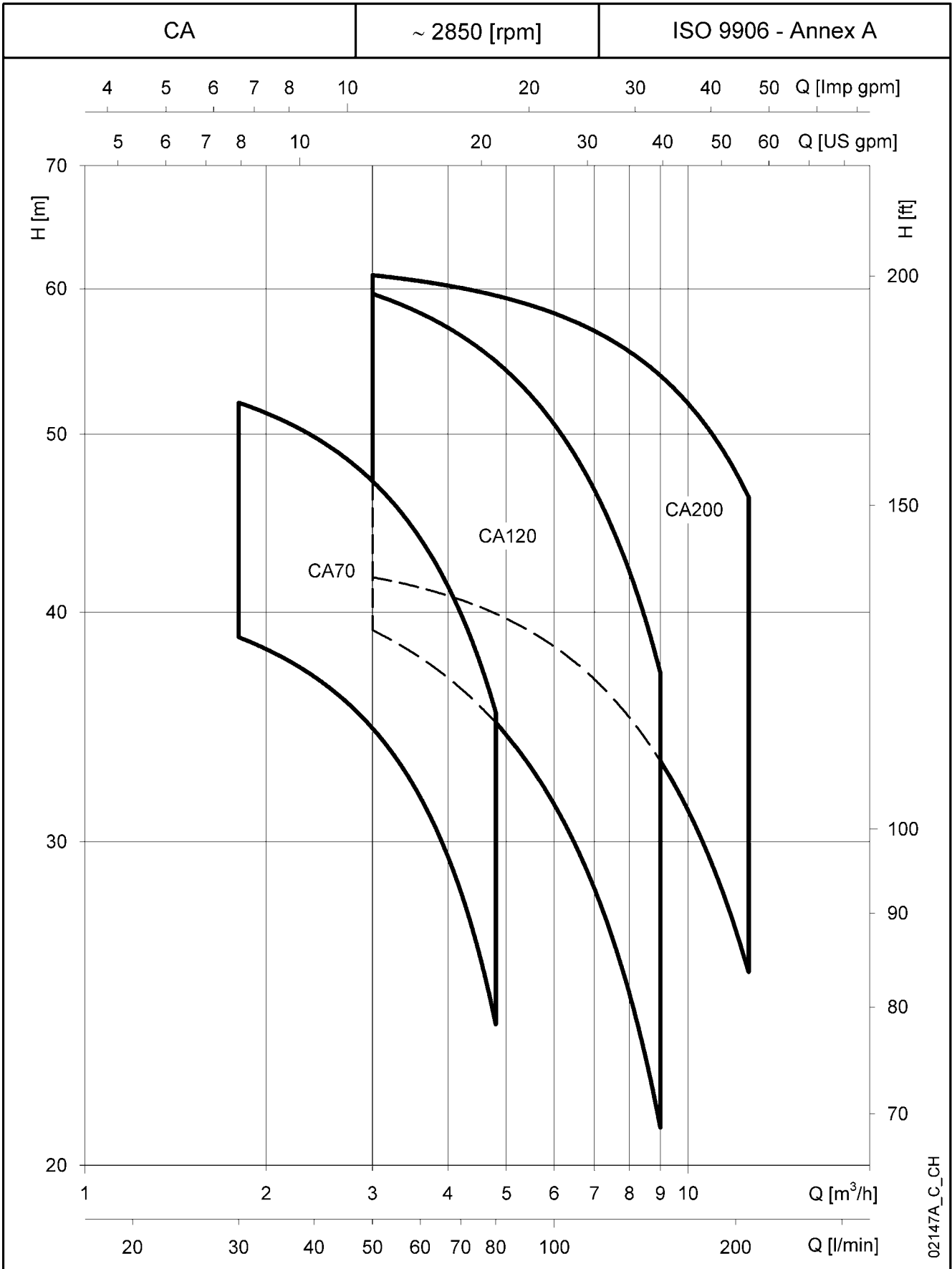

02147A\_C\_CH



# ITT

# Lowara

## CA70 SERIES OPERATING CHARACTERISTICS AT 50 Hz

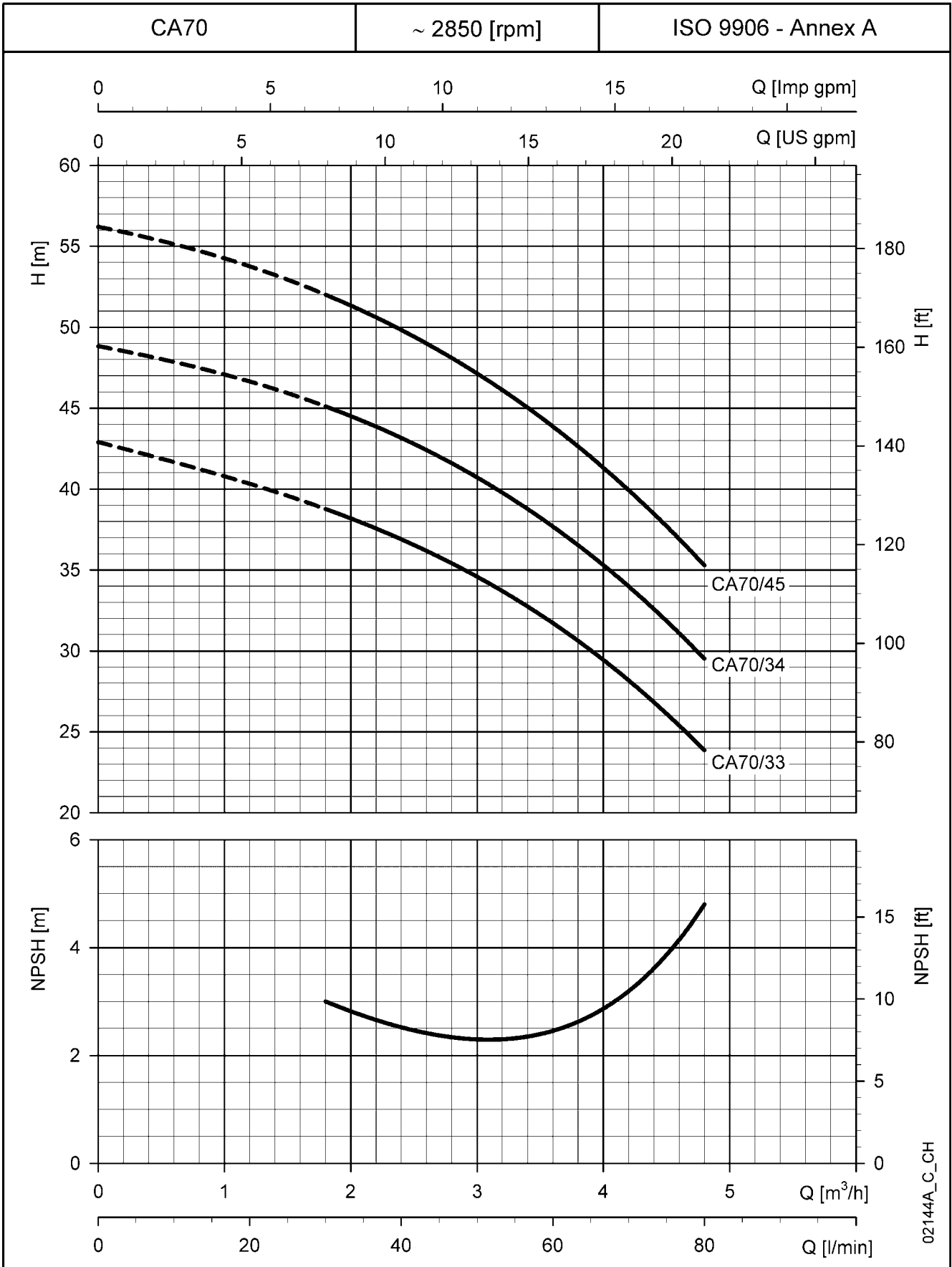

These performances are valid for liquids with density  $\rho = 1.0 \text{ Kg/dm}^3$  and kinematic viscosity  $\nu = 1 \text{ mm}^2/\text{sec}$ .



# ITT

# Lowara

## CA120 SERIES OPERATING CHARACTERISTICS AT 50 Hz

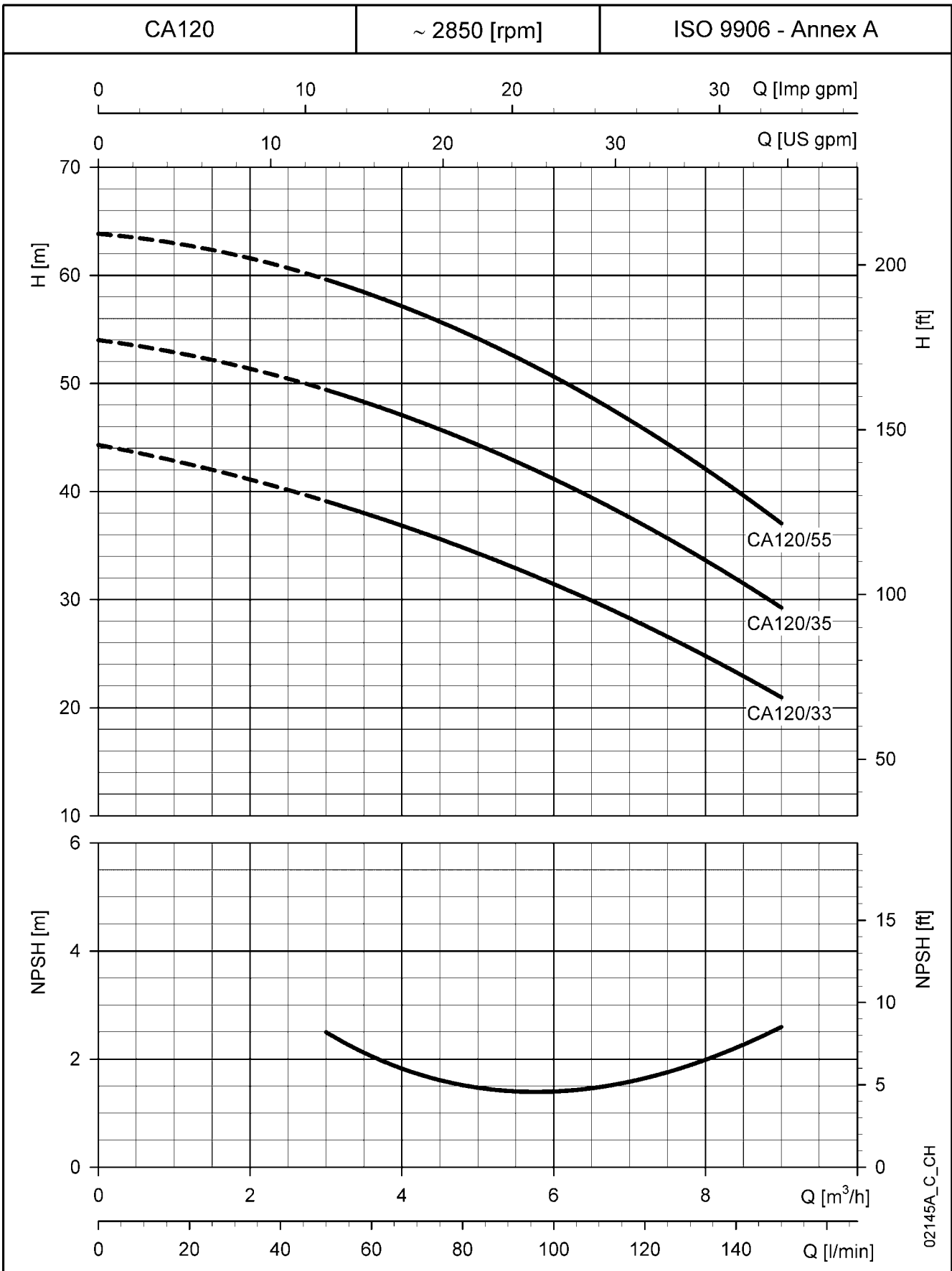

02145A\_C\_CH

These performances are valid for liquids with density  $\rho = 1.0 \text{ Kg/dm}^3$  and kinematic viscosity  $\nu = 1 \text{ mm}^2/\text{sec}$ .



# ITT

# Lowara

## CA200 SERIES OPERATING CHARACTERISTICS AT 50 Hz

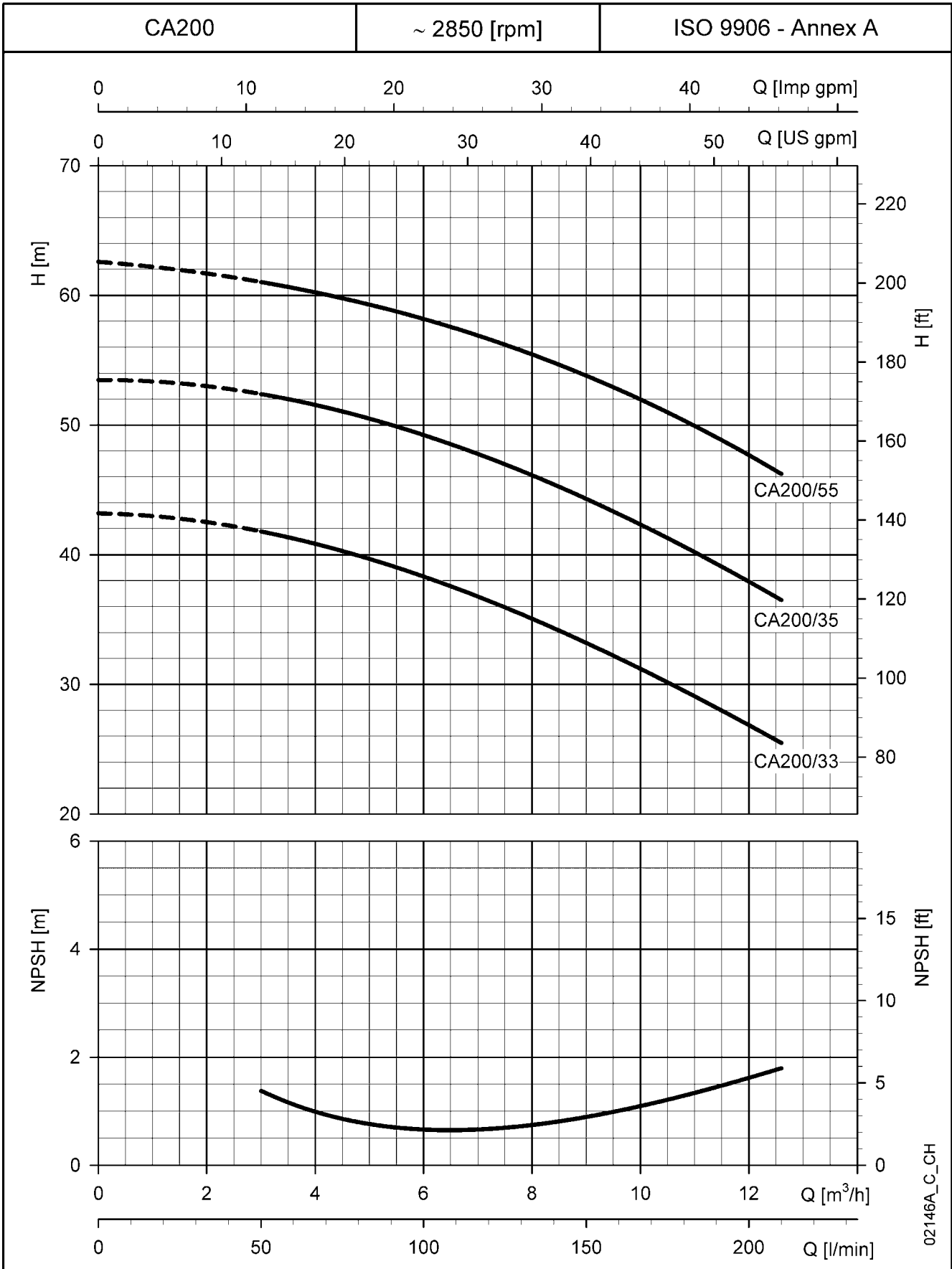

02146A\_C\_CH

These performances are valid for liquids with density  $\rho = 1.0 \text{ Kg/dm}^3$  and kinematic viscosity  $\nu = 1 \text{ mm}^2/\text{sec}$ .



# ITT

# Lowara

## CA-CA(N) SERIES DIMENSIONS AND WEIGHTS

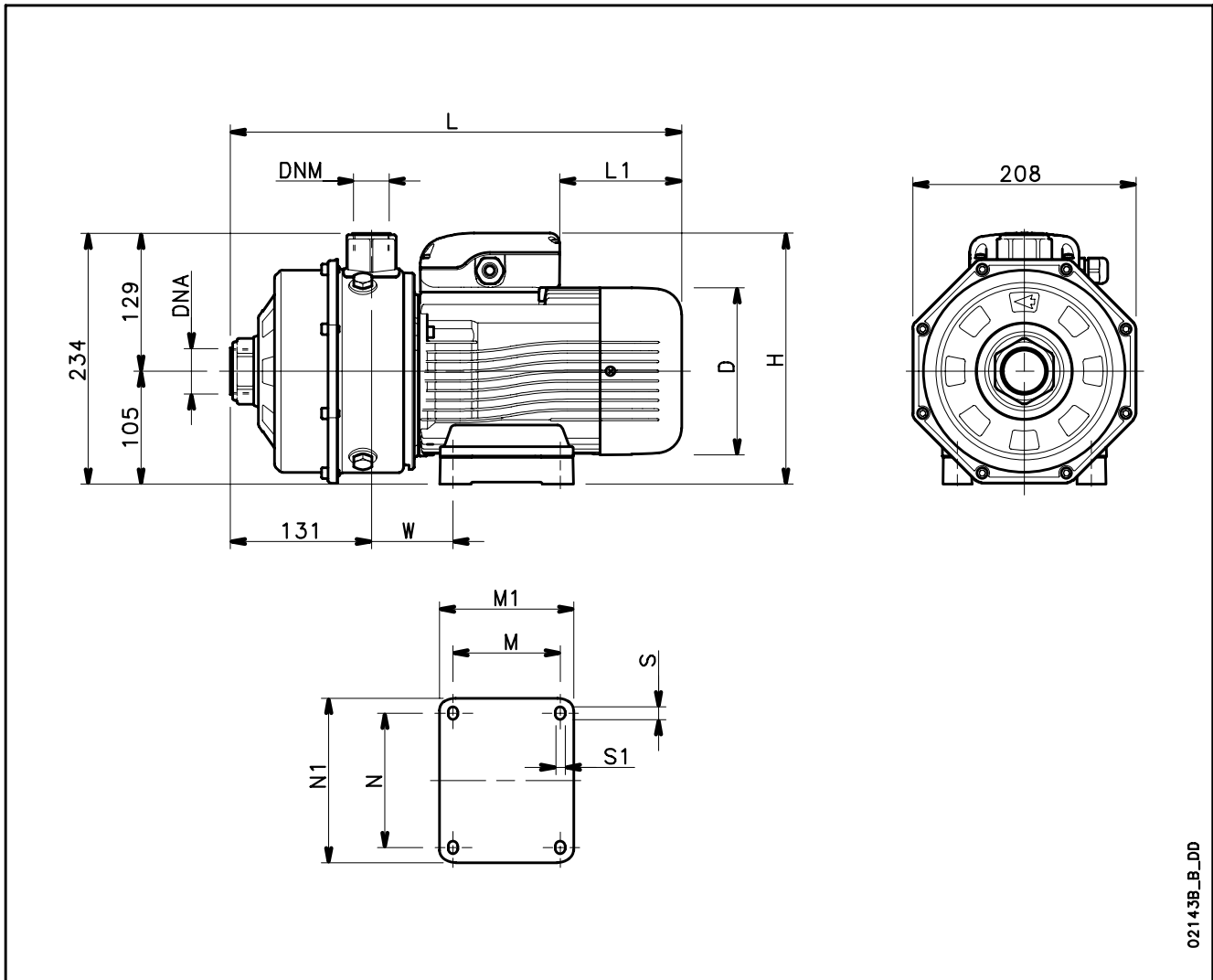

021\*3B\_B\_DD

PUMP TYPE	DIMENSIONS (mm)											DNA	DNM	WEIGHT kg
	D	H	L	L1	M	M1	N	N1	S	S1	W			
CAM 70/33	140	226	383	76	90	113	112	135	12	7	66	Rp 1/4	Rp 1	15
CAM 70/34	140	235	383	31	90	113	112	135	12	7	66	Rp 1/4	Rp 1	15,8
CAM 70/45	156	242	420	69	100	125	125	153	12	9	76	Rp 1/4	Rp 1	18,5
CAM 120/33	156	242	420	69	100	125	125	153	12	9	76	Rp 1/4	Rp 1	18,4
CAM 120/35	156	242	420	69	100	125	125	153	12	9	76	Rp 1/4	Rp 1	20,2
CAM 120/55*	174	239	454	84	125	155	140	170	13	10	98	Rp 1/4	Rp 1	27
CAM 200/33*	174	239	454	84	125	155	140	170	13	10	98	Rp 1/2	Rp 1	27
CAM 200/35*	174	239	454	84	125	155	140	170	13	10	98	Rp 1/2	Rp 1	27
CA 70/33	140	226	383	76	90	113	112	135	12	7	66	Rp 1/4	Rp 1	14,9
CA 70/34	140	226	383	76	90	113	112	135	12	7	66	Rp 1/4	Rp 1	15,7
CA 70/45	156	234	420	114	100	125	125	153	12	9	76	Rp 1/4	Rp 1	17
CA 120/33	156	234	420	114	100	125	125	153	12	9	76	Rp 1/4	Rp 1	16,8
CA120/35	156	234	420	114	100	125	125	153	12	9	76	Rp 1/4	Rp 1	18,7
CA 120/55	156	234	420	114	100	125	125	153	12	9	76	Rp 1/4	Rp 1	20,3
CA 200/33	156	234	420	114	100	125	125	153	12	9	76	Rp 1/2	Rp 1	20
CA 200/35*	174	239	454	172	125	155	140	170	13	10	98	Rp 1/2	Rp 1	25
CA 200/55*	174	239	454	172	125	155	140	170	13	10	98	Rp 1/2	Rp 1	27

\* Electric pumps equipped with PLM motors.



**ITT**

**Lowara**

# **TECHNICAL APPENDIX**

**TYPICAL APPLICATIONS CEA AND CA SERIES ELECTRIC PUMPS***Water Purification:*

Filtration  
De-ionized water  
Water treatment  
Commercial and residential pools

*Plastic Industry:*

Temperature Regulators  
Extrusion machines  
Manufacture of polymers

*Agricultural Residential Applications:*

Irrigation  
Greenhouses  
Humidifiers  
Water supply

*Heating, Ventilating & Air**Conditioning:*

Air scrubbers  
Water re-circulation  
Cooling towers  
Cooling systems  
Temperature control  
Chillers  
Induction heating  
Heat exchangers  
Water heating  
Booster packages

*General Industry:*

Spray booths  
Light chemical transfer  
Booster systems

*Medical:*

Laser cooling  
Massage  
Medical chillers  
Sanitary equipment

*Waste Management:*

Waste treatment  
Pollution control

*Machine Tool:*

Degreasing  
Parts washing  
Chemical treatment  
Heat treatment

*Graphics:*

Film washing  
Cooling processes

*Marine Sector:*

Water on board ships

*Computers:*

Circuit board washing  
Unit cooling

*Laundry:*

Commercial washers

*Food and Drink:*

Food processing  
Bottle washing  
Citrus processing  
Dishwashing  
Brewing  
Sanitary ware



ITT

Lowara

CEA - CA SERIES

standard configuration: carbon/ceramic mechanical seal, NBR O-rings  
Compatibility chart for most commonly used liquids, for other compatible liquids refer to our web page [www.lowara.com](http://www.lowara.com)

LIQUIDO LIQUID	FORMULA	CONCENTRAZIONE CONCENTRATION %	TEMPERATURA TEMPERATURE - MIN (°C) - MAX (°C)	PESO SPEC. DENSITY kg/dm <sup>3</sup>	mechanical seal materials		TENUTA MECCANICA MECHANICAL SEAL			
					mechanical seal	o-ring	STD	number A	number P	number N
Acido Acetico Acetic acid configuration code	CH <sub>3</sub> CO OH	80	-5 +70	1.05	Carb. di tung. - Carb. di sil. ...XPB	EPDM	3	3	1	3
Acido Citrico Citric acid configuration code	C <sub>6</sub> H <sub>8</sub> O <sub>7</sub>	5	-5 +70	1.54	carbon - ceramic ...XAA	FPM	2	1	2	2
Acido Fosforico Phosphoric acid configuration code	H <sub>3</sub> PO <sub>4</sub>	20	-5 +30	1.33	Carb. di tung. - Carb. di sil. ...XPB	EPDM	3	2	1	1
Acqua Water configuration code	H <sub>2</sub> O	100	-5 +85		carbon - ceramic standard product	NBR	1	1	1	1
Acqua Deionizzata Water deionized configuration code		100	-5 +85		carbon - ceramic ...XAA	FPM				
Acqua Demineralizzata Water demineralized configuration code		100	-5 +85		carbon - ceramic standard product	NBR				
Acqua di mare (4) Sea water (4) configuration code		/	-5 +25		not recommended					
Alcool Butilico Butyl alcohol configuration code	CH <sub>3</sub> (CH <sub>2</sub> ) <sub>7</sub> CH <sub>2</sub> OH	100	-5 +80	0.81	carbon - ceramic standard product	NBR	1	1	2	1
Alcool Etilico Ethyl alcohol (Ethanol) configuration code		100	-5 +40	0.81	carbon - ceramic standard product	NBR				
Alcool Metilico Methyl alcohol configuration code	CH <sub>3</sub> OH	100	-5 +40	0.79	carbon - ceramic standard product	NBR	1	3	1	3
Cloroformio Chloroform configuration code	CHCl <sub>3</sub>	/	-5 +30	1.48	Carb. di tung. - Carb. di sil. ...XNA	FPM	3	2	3	1
Freon 112	CCl <sub>2</sub> FCCl <sub>2</sub> F	100	-5	1.57			2	2	3	1



configuration_code										Carb. di tung. - Carb. di sil. ...XNA	FPM						
Freon 113								+30									
Triclorotrifluoroetano						100		-5	1.42						1	2	3
configuration_code								+30									
Glicole Etilenico						50		-5	1.13								
Ethylene glycol								+80							2	2	1
configuration_code																	
Ipcolorito di sodio	(1)					0.5		-5									
Sodium hypochlorite								+25									
configuration_code																	
Olio di Ricino						100		-5									
Castor Oil								+85									
configuration_code																	
Olio Minerale						100		-5	0.94								
Mineral oil								+85									
configuration_code																	
Soda Caustica						25		0	2.13								
Cautic Soda								+70									
configuration_code																	
Tricloroetilene / Trichloroethylene						/		-5	1.46								
(Trielina)	(1)							+40									
configuration_code																	

(X) - Richiesto battente positivo / Positive suction head required

1 = COMPATIBILITA' BUONA  
2 = COMPATIBILITA' MEDIOCRE  
3 = NON COMPATIBILE

1 = GOOD COMPATIBILITY  
2 = POOR COMPATIBILITY  
3 = NO COMPATIBILITY

(1)-Liquido pericoloso (tossico,velenoso,ustionabile ecc.)  
-Dangerous liquid (toxic,poisonous,attacks skin,irritant,etc.)  
(2)-Liquido infiammabile ed esplosivo  
-Flammable and explosive liquid  
(3)-Solo versioni a 4 poli. Four poles versions only.  
(4) La compatibilità dell'acciaio inossidabile dipende dal contenuto di cloro in rapporto alla temperatura del liquido, è necessaria un'analisi più dettagliata

## WATER REQUIREMENTS IN CIVIL USERS

Determination of the water requirement depends on the type of users and contemporaneity factor. The calculation may be subject to regulations, standards or customs that may vary from country to country. The calculation method shown below is an example based on practical experience, designed to provide a reference value and not a substitute for detailed analytical calculation.

### Water requirements in condominiums

The **consumption table** shows the maximum values for each delivery point, depending on the plumbing amenities.

### MAXIMUM CONSUMPTION FOR EACH DELIVERY POINT

TYPE	CONSUMPTION (l/min)
Sink	9
Dishwasher	10
Washing machine	12
Shower	12
Bathtub	15
Washbasin	6
Bidet	6
Flush tank WC	6
Controlled flushing system WC	90

G-at-cm\_a\_th

The **sum of the water consumption values** of each delivery point determines the maximum theoretical requirement, which must be reduced according to the **contemporaneity coefficient**, because in actual fact the delivery points are never used all together.

$$f = \frac{1}{\sqrt{(0,857 \times Nr \times Na)}} \quad \text{Coefficient for apartments with one bathroom and flush tank WC}$$

$$f = \frac{1}{\sqrt{(0,857 \times Nr \times Na)}} \quad \text{Coefficient for apartments with one bathroom and controlled flushing system WC}$$

$$f = \frac{1,03}{\sqrt{(0,545 \times Nr \times Na)}} \quad \text{Coefficient for apartments with two bathrooms and flush tank WC}$$

$$f = \frac{0,8}{\sqrt{(0,727 \times Nr \times Na)}} \quad \text{Coefficient for apartments with two bathrooms and controlled flushing system WC}$$

f= coefficient; Nr= number of delivery points; Na= number of apartments

The **table of water requirements in civil users** shows the maximum contemporaneity flow-rate values based on the **number of apartments** and the type of WC for apartments with one bathroom and two bathrooms. As regards apartments with one bathroom, 7 drawing points have been taken into consideration, while 11 points have been considered for apartments with two bathrooms. If the number of drawing points or apartments is different, use the formulas to **calculate** the requirement.



## TABLE OF WATER REQUIREMENTS IN CIVIL USERS

NUMBER OF APARTMENTS	WITH FLUSH TANK WC		WITH CONTROLLED FLUSHING SYSTEM WC	
	1	2	1	2
FLOW RATE (l/min)				
1	32	40	60	79
2	45	56	85	111
3	55	68	105	136
4	63	79	121	157
5	71	88	135	176
6	78	97	148	193
7	84	105	160	208
8	90	112	171	223
9	95	119	181	236
10	100	125	191	249
11	105	131	200	261
12	110	137	209	273
13	114	143	218	284
14	119	148	226	295
15	123	153	234	305
16	127	158	242	315
17	131	163	249	325
18	134	168	256	334
19	138	172	263	343
20	142	177	270	352
21	145	181	277	361
22	149	185	283	369
23	152	190	290	378
24	155	194	296	386
25	158	198	302	394
26	162	202	308	401
27	165	205	314	409
28	168	209	320	417
29	171	213	325	424
30	174	217	331	431
35	187	234	357	466
40	200	250	382	498
45	213	265	405	528
50	224	280	427	557
55	235	293	448	584
60	245	306	468	610
65	255	319	487	635
70	265	331	506	659
75	274	342	523	682
80	283	354	540	704
85	292	364	557	726
90	301	375	573	747
95	309	385	589	767
100	317	395	604	787
120	347	433	662	863
140	375	468	715	932
160	401	500	764	996
180	425	530	811	1056
200	448	559	854	1114

For seaside resorts, a flow rate increased by at least 20% must be considered.

G-at-fi\_a\_th



### WATER REQUIREMENTS FOR COMMUNITY BUILDINGS

The requirements of buildings intended for specific uses, such as **offices, residential units, hotels, department stores, nursing homes** and so on, are different from those of condominiums, and both their global daily water consumption and the maximum contemporaneity flow rate are usually greater. The **diagram of water requirements for community buildings** shows the maximum contemporaneity flow rate of some types of communities, for guidance.

These requirements must be determined case by case with the utmost accuracy, using analytical calculation methods, according to particular needs and local provisions.

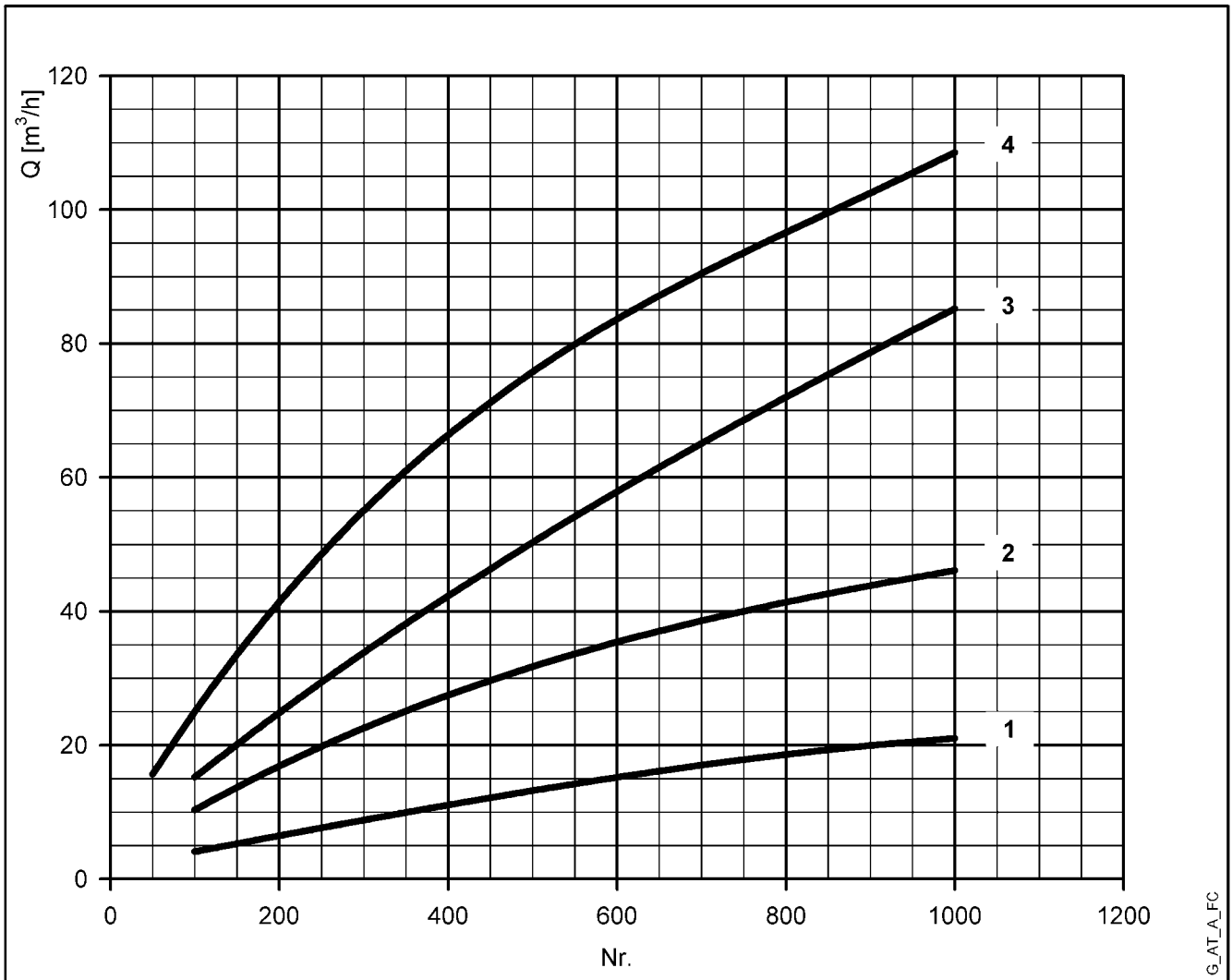

For seaside resorts, the flow rate must be increased by at least 20%.

- 1 = Offices (N. of people)
- 2 = Department stores (N. of people)
- 3 = Nursing homes (N. of beds)
- 4 = Hotels, residences (N. of beds)

## NPSH

The minimum operating values that can be reached at the pump suction end are limited by the onset of cavitation.

Cavitation is the formation of vapour-filled cavities within liquids where the pressure is locally reduced to a critical value, or where the local pressure is equal to, or just below the vapour pressure of the liquid.

The vapour-filled cavities flow with the current and when they reach a higher pressure area the vapour contained in the cavities condenses. The cavities collide, generating pressure waves that are transmitted to the walls. These, being subjected to stress cycles, gradually become deformed and yield due to fatigue. This phenomenon, characterized by a metallic noise produced by the hammering on the pipe walls, is called incipient cavitation.

The damage caused by cavitation may be magnified by electrochemical corrosion and a local rise in temperature due to the plastic deformation of the walls. The materials that offer the highest resistance to heat and corrosion are alloy steels, especially austenitic steel. The conditions that trigger cavitation may be assessed by calculating the total net suction head, referred to in technical literature with the acronym NPSH (Net Positive Suction Head).

The NPSH represents the total energy (expressed in m.) of the liquid measured at suction under conditions of incipient cavitation, excluding the vapour pressure (expressed in m.) that the liquid has at the pump inlet.

To find the static height  $h_z$  at which to install the machine under safe conditions, the following formula must be verified:

$$h_p + h_z \geq (\text{NPSH}_r + 0.5) + h_f + h_{pv} \quad \textcircled{1}$$

where:

**h<sub>p</sub>** is the absolute pressure applied to the free liquid surface in the suction tank, expressed in m. of liquid;  $h_p$  is the quotient between the barometric pressure and the specific weight of the liquid.

**h<sub>z</sub>** is the suction lift between the pump axis and the free liquid surface in the suction tank, expressed in m.;  $h_z$  is negative when the liquid level is lower than the pump axis.

**h<sub>f</sub>** is the flow resistance in the suction line and its accessories, such as: fittings, foot valve, gate valve, elbows, etc.

**h<sub>pv</sub>** is the vapour pressure of the liquid at the operating temperature, expressed in m. of liquid.  $h_{pv}$  is the quotient between the Pv vapour pressure and the liquid's specific weight.

**0,5** is the safety factor.

The maximum possible suction head for installation depends on the value of the atmospheric pressure (i.e. the elevation above sea level at which the pump is installed) and the temperature of the liquid.

To help the user, with reference to water temperature (4° C) and to the elevation above sea level, the following tables show the drop in hydraulic pressure head in relation to the elevation above sea level, and the suction loss in relation to temperature.

<b>Water temperature (°C)</b>	20	40	60	80	90	110	120
<b>Suction loss (m)</b>	0,2	0,7	2,0	5,0	7,4	15,4	21,5

<b>Elevation above sea level (m)</b>	500	1000	1500	2000	2500	3000
<b>Suction loss (m)</b>	0,55	1,1	1,65	2,2	2,75	3,3

Friction loss is shown in the tables at pages 36-37 of this catalogue. To reduce it to a minimum, especially in cases of high suction head (over 4-5 m.) or within the operating limits with high flow rates, we recommend using a suction line having a larger diameter than that of the pump's suction port. It is always a good idea to position the pump as close as possible to the liquid to be pumped.

Make the following calculation:

Liquid: water at ~15°C  $\gamma = 1 \text{ kg/dm}^3$

Flow rate required: 30 m<sup>3</sup>/h

Head for required delivery: 43 m.

Suction lift: 3,5 m.

The selection is an FHE 40-200/75 pump whose NPSH required value is, at 30 m<sup>3</sup>/h, di 2,5 m.

For water at 15 °C

$$h_p = P_a / \gamma = 10,33\text{m}, h_{pv} = P_v / \gamma = 0,174\text{m} (0,01701 \text{ bar})$$

The  $H_f$  flow resistance in the suction line with foot valves is ~ 1,2 m.

By substituting the parameters in formula  $\textcircled{1}$  with the numeric values above, we have:

$$10,33 + (-3,5) \geq (2,5 + 0,5) + 1,2 + 0,17$$

from which we have: 6,8 > 4,4

The relation is therefore verified.



# ITT

# Lowara

## TECHNICAL APPENDIX VAPOUR PRESSURE PS VAPOUR PRESSURE AND $\rho$ DENSITY OF WATER TABLE

t °C	T K	ps bar	$\rho$ kg/dm <sup>3</sup>	t °C	T K	ps bar	$\rho$ kg/dm <sup>3</sup>	t °C	T K	ps bar	$\rho$ kg/dm <sup>3</sup>
0	273,15	0,00611	0,9998	55	328,15	0,15741	0,9857	120	393,15	1,9854	0,9429
1	274,15	0,00657	0,9999	56	329,15	0,16511	0,9852	122	395,15	2,1145	0,9412
2	275,15	0,00706	0,9999	57	330,15	0,17313	0,9846	124	397,15	2,2504	0,9396
3	276,15	0,00758	0,9999	58	331,15	0,18147	0,9842	126	399,15	2,3933	0,9379
4	277,15	0,00813	1,0000	59	332,15	0,19016	0,9837	128	401,15	2,5435	0,9362
5	278,15	0,00872	1,0000	60	333,15	0,1992	0,9832	130	403,15	2,7013	0,9346
6	279,15	0,00935	1,0000	61	334,15	0,2086	0,9826	132	405,15	2,867	0,9328
7	280,15	0,01001	0,9999	62	335,15	0,2184	0,9821	134	407,15	3,041	0,9311
8	281,15	0,01072	0,9999	63	336,15	0,2286	0,9816	136	409,15	3,223	0,9294
9	282,15	0,01147	0,9998	64	337,15	0,2391	0,9811	138	411,15	3,414	0,9276
10	283,15	0,01227	0,9997	65	338,15	0,2501	0,9805	140	413,15	3,614	0,9258
11	284,15	0,01312	0,9997	66	339,15	0,2615	0,9799	145	418,15	4,155	0,9214
12	285,15	0,01401	0,9996	67	340,15	0,2733	0,9793	155	428,15	5,433	0,9121
13	286,15	0,01497	0,9994	68	341,15	0,2856	0,9788	160	433,15	6,181	0,9073
14	287,15	0,01597	0,9993	69	342,15	0,2984	0,9782	165	438,15	7,008	0,9024
15	288,15	0,01704	0,9992	70	343,15	0,3116	0,9777	170	443,15	7,920	0,8973
16	289,15	0,01817	0,9990	71	344,15	0,3253	0,9770	175	448,15	8,924	0,8921
17	290,15	0,01936	0,9988	72	345,15	0,3396	0,9765	180	453,15	10,027	0,8869
18	291,15	0,02062	0,9987	73	346,15	0,3543	0,9760	185	458,15	11,233	0,8815
19	292,15	0,02196	0,9985	74	347,15	0,3696	0,9753	190	463,15	12,551	0,8760
20	293,15	0,02337	0,9983	75	348,15	0,3855	0,9748	195	468,15	13,987	0,8704
21	294,15	0,24850	0,9981	76	349,15	0,4019	0,9741	200	473,15	15,550	0,8647
22	295,15	0,02642	0,9978	77	350,15	0,4189	0,9735	205	478,15	17,243	0,8588
23	296,15	0,02808	0,9976	78	351,15	0,4365	0,9729	210	483,15	19,077	0,8528
24	297,15	0,02982	0,9974	79	352,15	0,4547	0,9723	215	488,15	21,060	0,8467
25	298,15	0,03166	0,9971	80	353,15	0,4736	0,9716	220	493,15	23,198	0,8403
26	299,15	0,03360	0,9968	81	354,15	0,4931	0,9710	225	498,15	25,501	0,8339
27	300,15	0,03564	0,9966	82	355,15	0,5133	0,9704	230	503,15	27,976	0,8273
28	301,15	0,03778	0,9963	83	356,15	0,5342	0,9697	235	508,15	30,632	0,8205
29	302,15	0,04004	0,9960	84	357,15	0,5557	0,9691	240	513,15	33,478	0,8136
30	303,15	0,04241	0,9957	85	358,15	0,5780	0,9684	245	518,15	36,523	0,8065
31	304,15	0,04491	0,9954	86	359,15	0,6011	0,9678	250	523,15	39,776	0,7992
32	305,15	0,04753	0,9951	87	360,15	0,6249	0,9671	255	528,15	43,246	0,7916
33	306,15	0,05029	0,9947	88	361,15	0,6495	0,9665	260	533,15	46,943	0,7839
34	307,15	0,05318	0,9944	89	362,15	0,6749	0,9658	265	538,15	50,877	0,7759
35	308,15	0,05622	0,9940	90	363,15	0,7011	0,9652	270	543,15	55,058	0,7678
36	309,15	0,05940	0,9937	91	364,15	0,7281	0,9644	275	548,15	59,496	0,7593
37	310,15	0,06274	0,9933	92	365,15	0,7561	0,9638	280	553,15	64,202	0,7505
38	311,15	0,06624	0,9930	93	366,15	0,7849	0,9630	285	558,15	69,186	0,7415
39	312,15	0,06991	0,9927	94	367,15	0,8146	0,9624	290	563,15	74,461	0,7321
40	313,15	0,07375	0,9923	95	368,15	0,8453	0,9616	295	568,15	80,037	0,7223
41	314,15	0,07777	0,9919	96	369,15	0,8769	0,9610	300	573,15	85,927	0,7122
42	315,15	0,08198	0,9915	97	370,15	0,9094	0,9602	305	578,15	92,144	0,7017
43	316,15	0,09639	0,9911	98	371,15	0,9430	0,9596	310	583,15	98,70	0,6906
44	317,15	0,09100	0,9907	99	372,15	0,9776	0,9586	315	588,15	105,61	0,6791
45	318,15	0,09582	0,9902	100	373,15	1,0133	0,9581	320	593,15	112,89	0,6669
46	319,15	0,10086	0,9898	102	375,15	1,0878	0,9567	325	598,15	120,56	0,6541
47	320,15	0,10612	0,9894	104	377,15	1,1668	0,9552	330	603,15	128,63	0,6404
48	321,15	0,11162	0,9889	106	379,15	1,2504	0,9537	340	613,15	146,05	0,6102
49	322,15	0,11736	0,9884	108	381,15	1,3390	0,9522	350	623,15	165,35	0,5743
50	323,15	0,12335	0,9880	110	383,15	1,4327	0,9507	360	633,15	186,75	0,5275
51	324,15	0,12961	0,9876	112	385,15	1,5316	0,9491	370	643,15	210,54	0,4518
52	325,15	0,13613	0,9871	114	387,15	1,6362	0,9476	374,15	647,30	221,20	0,3154
53	326,15	0,14293	0,9862	116	389,15	1,7465	0,9460				
54	327,15	0,15002	0,9862	118	391,15	1,8628	0,9445				

G-at\_nps\_h\_a\_sc



## TABLE OF FLOW RESISTANCE IN 100 m OF STRAIGHT CAST IRON PIPELINE (HAZEN-WILLIAMS FORMULA C=100)

FLOW RATE		NOMINAL DIAMETER in mm and INCHES																	
m <sup>3</sup> /h	l/min	15	20	25	32	40	50	65	80	100	125	150	175	200	250	300	350	400	
		1/2"	3/4"	1"	1 1/4"	1 1/2"	2	2 1/2"	3"	4"	5"	6"	7"	8"	10"	12"	14"	16"	
0,6	10	v	0,94	0,53	0,34	0,21	0,13												
		hr	16	3,94	1,33	0,40	0,13												
0,9	15	v	1,42	0,80	0,51	0,31	0,20												
		hr	33,9	8,35	2,82	0,85	0,29												
1,2	20	v	1,89	1,06	0,68	0,41	0,27	0,17											
		hr	57,7	14,21	4,79	1,44	0,49	0,16											
1,5	25	v	2,36	1,33	0,85	0,52	0,33	0,21											
		hr	87,2	21,5	7,24	2,18	0,73	0,25											
1,8	30	v	2,83	1,59	1,02	0,62	0,40	0,25											
		hr	122	30,1	10,1	3,05	1,03	0,35											
2,1	35	v	3,30	1,86	1,19	0,73	0,46	0,30											
		hr	162	40,0	13,5	4,06	1,37	0,46											
2,4	40	v		2,12	1,36	0,83	0,53	0,34	0,20										
		hr		51,2	17,3	5,19	1,75	0,59	0,16										
3	50	v		2,65	1,70	1,04	0,66	0,42	0,25										
		hr		77,4	26,1	7,85	2,65	0,89	0,25										
3,6	60	v		3,18	2,04	1,24	0,80	0,51	0,30										
		hr		108	36,6	11,0	3,71	1,25	0,35										
4,2	70	v		3,72	2,38	1,45	0,93	0,59	0,35										
		hr		144	48,7	14,6	4,93	1,66	0,46										
4,8	80	v		4,25	2,72	1,66	1,06	0,68	0,40										
		hr		185	62,3	18,7	6,32	2,13	0,59										
5,4	90	v			3,06	1,87	1,19	0,76	0,45	0,30									
		hr			77,5	23,3	7,85	2,65	0,74	0,27									
6	100	v			3,40	2,07	1,33	0,85	0,50	0,33									
		hr			94,1	28,3	9,54	3,22	0,90	0,33									
7,5	125	v			4,25	2,59	1,66	1,06	0,63	0,41									
		hr			142	42,8	14,4	4,86	1,36	0,49									
9	150	v				3,11	1,99	1,27	0,75	0,50	0,32								
		hr				59,9	20,2	6,82	1,90	0,69	0,23								
10,5	175	v				3,63	2,32	1,49	0,88	0,58	0,37								
		hr				79,7	26,9	9,07	2,53	0,92	0,31								
12	200	v				4,15	2,65	1,70	1,01	0,66	0,42								
		hr				102	34,4	11,6	3,23	1,18	0,40								
15	250	v				5,18	3,32	2,12	1,26	0,83	0,53	0,34							
		hr				154	52,0	17,5	4,89	1,78	0,60	0,20							
18	300	v					3,98	2,55	1,51	1,00	0,64	0,41							
		hr					72,8	24,6	6,85	2,49	0,84	0,28							
24	400	v					5,31	3,40	2,01	1,33	0,85	0,54	0,38						
		hr					124	41,8	11,66	4,24	1,43	0,48	0,20						
30	500	v					6,63	4,25	2,51	1,66	1,06	0,68	0,47						
		hr					187	63,2	17,6	6,41	2,16	0,73	0,30						
36	600	v					5,10	3,02	1,99	1,27	0,82	0,57	0,42						
		hr					88,6	24,7	8,98	3,03	1,02	0,42	0,20						
42	700	v					5,94	3,52	2,32	1,49	0,95	0,66	0,49						
		hr					118	32,8	11,9	4,03	1,36	0,56	0,26						
48	800	v					6,79	4,02	2,65	1,70	1,09	0,75	0,55						
		hr					151	42,0	15,3	5,16	1,74	0,72	0,34						
54	900	v					7,64	4,52	2,99	1,91	1,22	0,85	0,62						
		hr					188	52,3	19,0	6,41	2,16	0,89	0,42						
60	1000	v					5,03	3,32	2,12	1,36	0,94	0,69	0,53						
		hr					63,5	23,1	7,79	2,63	1,08	0,51	0,27						
75	1250	v					6,28	4,15	2,65	1,70	1,18	0,87	0,66						
		hr					96,0	34,9	11,8	3,97	1,63	0,77	0,40						
90	1500	v					7,54	4,98	3,18	2,04	1,42	1,04	0,80						
		hr					134	48,9	16,5	5,57	2,29	1,08	0,56						
105	1750	v					8,79	5,81	3,72	2,38	1,65	1,21	0,93						
		hr					179	65,1	21,9	7,40	3,05	1,44	0,75						
120	2000	v					6,63	4,25	2,72	1,89	1,39	1,06	0,68						
		hr					83,3	28,1	9,48	3,90	1,84	0,96	0,32						
150	2500	v					8,29	5,31	3,40	2,36	1,73	1,33	0,85						
		hr					126	42,5	14,3	5,89	2,78	1,45	0,49						
180	3000	v							6,37	4,08	2,83	2,08	1,59						
		hr							59,5	20,1	8,26	3,90	2,03	0,69			0,71	0,28	
210	3500	v							7,43	4,76	3,30	2,43	1,86						
		hr							79,1	26,7	11,0	5,18	2,71	1,19			0,83	0,38	
240	4000	v							8,49	5,44	3,77	2,77	2,12						
		hr							101	34,2	14,1	6,64	3,46	1,17			0,94	0,48	
300	5000	v								6,79	4,72	3,47	2,65						
		hr								51,6	21,2	10,0	5,23	1,77			1,18	0,73	
360	6000	v								8,15	5,66	4,16	3,18						
		hr								72,3	29,8	14,1	7,33	2,47			1,42	1,02	
420	7000	v									6,61	4,85	3,72						
		hr									39,6	18,7	9,75	3,29			1,65	1,21	0,64
480	8000	v									7,55	5,55	4,25						
		hr									50,7	23,9	12,49	4,21			1,89	1,39	0,82
540	9000	v									8,49	6,24	4,78						
		hr									63,0	29,8	15,5	5,24			2,12	1,56	1,19
																	1,02	0,73	0,53
600	10000	v										6,93	5,31						
		hr										36,2	18,9				2,36	1,73	1,33
																	2,62	1,24	0,65

The hr values must be multiplied by:  
 0.71 for galvanized or painted steel pipes  
 0.54 for stainless steel or copper pipes  
 0.47 for PVC or PE pipes

hr = flow resistance for 100m of straight pipeline (m)  
 V = water speed (m/s)

G-at-pct\_a\_th

**FLOW RESISTANCE**
**TABLE OF FLOW RESISTANCE IN BENDS, VALVES AND GATES**

The flow resistance is calculated using the equivalent pipeline length method according to the table below:

ACCESSORY TYPE	DN											
	25	32	40	50	65	80	100	125	150	200	250	300
	Equivalent pipeline length (m)											
45° bend	0,2	0,2	0,4	0,4	0,6	0,6	0,9	1,1	1,5	1,9	2,4	2,8
90° bend	0,4	0,6	0,9	1,1	1,3	1,5	2,1	2,6	3,0	3,9	4,7	5,8
90° smooth bend	0,4	0,4	0,4	0,6	0,9	1,1	1,3	1,7	1,9	2,8	3,4	3,9
Union tee or cross	1,1	1,3	1,7	2,1	2,6	3,2	4,3	5,3	6,4	7,5	10,7	12,8
Gate	-	-	-	0,2	0,2	0,2	0,4	0,4	0,6	0,9	1,1	1,3
Non return valve	1,1	1,5	1,9	2,4	3,0	3,4	4,7	5,9	7,4	9,6	11,8	13,9

G-a-pcv\_a\_th

The table is valid for the Hazen Williams coefficient  $C = 100$  (cast iron pipework). For steel pipework, multiply the values by 1.41. For stainless steel, copper and coated cast iron pipework, multiply the values by 1.85.

When the **equivalent pipeline length** has been determined, the flow resistance is obtained from the table of flow resistance.

The values given are guideline values which are bound to vary slightly according to the model, especially for gate valves and non-return valves, for which it is a good idea to check the values supplied by the manufacturers.



## VOLUMETRIC CAPACITY

Litres per minute l/min	Cubic metres per hour m <sup>3</sup> /h	Cubic feet per hour ft <sup>3</sup> /h	Cubic feet per minute ft <sup>3</sup> /min	Imp. gal. per minute Imp. gal./min	US gal. per minute Us gal./min
<b>1,0000</b>	0,0600	2,1189	0,0353	0,2200	0,2640
16,6667	<b>1,0000</b>	35,3147	0,5886	3,6660	4,4030
0,4720	0,0283	<b>1,0000</b>	0,0167	0,1040	0,1250
28,3170	1,6990	60,0000	<b>1,0000</b>	6,2290	7,4800
4,5460	0,2728	9,6326	0,1605	<b>1,0000</b>	1,2010
3,7850	0,2271	8,0209	0,1337	0,8330	<b>1,0000</b>

## PRESSURE AND HEAD

Newton per square metre N/m <sup>2</sup>	kilo Pascal kPa	bar bar	Pound force per square inch psi	metre of water m H <sub>2</sub> O	millimetre di mercury mm Hg
<b>1,0000</b>	0,0010	1 x 10 <sup>-5</sup>	1,45 x 10 <sup>-4</sup>	1,02 x 10 <sup>-4</sup>	0,0075
1000,0000	<b>1,0000</b>	0,0100	0,1450	0,1020	7,5000
1 x 10 <sup>5</sup>	100,0000	<b>1,0000</b>	14,5000	10,2000	750,1000
6895,0000	6,8950	0,0690	<b>1,0000</b>	0,7030	51,7200
9789,0000	9,7890	0,0980	1,4200	<b>1,0000</b>	73,4200
133,3000	0,1333	0,0013	0,0190	0,0140	<b>1,0000</b>

## LENGHT

millimetre mm	centimetre cm	metre m	inch in	foot ft	yard yd
<b>1,0000</b>	0,1000	0,0010	0,0394	0,0033	0,0011
10,0000	<b>1,0000</b>	0,0100	0,3937	0,0328	0,0109
1000,0000	100,0000	<b>1,0000</b>	39,3701	3,2808	1,0936
25,4000	2,5400	0,0254	<b>1,0000</b>	0,0833	0,0278
304,8000	30,4800	0,3048	12,0000	<b>1,0000</b>	0,3333
914,4000	91,4400	0,9144	36,0000	3,0000	<b>1,0000</b>

## VOLUME

cubic metre m <sup>3</sup>	litre litro	millilitre ml	imp. gallon imp. gal.	US gallon US gal.	cubic foot ft <sup>3</sup>
<b>1,0000</b>	1000,0000	1 x 10 <sup>6</sup>	220,0000	264,2000	35,3147
0,0010	<b>1,0000</b>	1000,0000	0,2200	0,2642	0,0353
1 x 10 <sup>-6</sup>	0,0010	<b>1,0000</b>	2,2 x 10 <sup>-4</sup>	2,642 x 10 <sup>-4</sup>	3,53 x 10 <sup>-5</sup>
0,0045	4,5460	4546,0000	<b>1,0000</b>	1,2010	0,1605
0,0038	3,7850	3785,0000	0,8327	<b>1,0000</b>	0,1337
0,0283	28,3170	28317,0000	6,2288	7,4805	<b>1,0000</b>

G-at\_pp-en\_a\_sc



**ITT Lowara part of ITT Corporation and headquarters of "Residential and Commercial Water - EMEA".**

World leading in offering high reliable fluid handling solutions for Building Services, Irrigation and Industrial applications. We provide a complete range of high quality pumps, packaged systems and controls and are specialized in engineering and manufacturing stainless steel products.

ITT Lowara is headquartered in Vicenza, Italy and operates in more than 80 countries across the world with own plants in Italy, Austria, Poland and Hungary. The company has 1.300 employees and generated 2008 sales exceeding \$440 million. ITT Lowara is wholly owned by the ITT Corporation of White Plains, New York, and is the EMEA headquarter of ITT's Residential and Commercial Water division. ITT Corporation is a high-technology engineering and manufacturing company operating on all seven continents in three vital markets: water and fluids management, global defense and security, motion and flow control. ITT Corporation generated 2008 sales of \$11.7 billion

**ITT RESIDENTIAL AND COMMERCIAL WATER DIVISION - EMEA**

**Headquarters**

**LOWARA S.r.l. Unipersonale**  
**Via Dott. Lombardi, 14**  
**36075 Montecchio Maggiore**  
**Vicenza - Italy**  
**Tel. (+39) 0444 707111**  
**Fax (+39) 0444 492166**  
**e-mail: lowara.mkt@itt.com**  
**http://www.lowara.com**

**AUSTRIA**  
**ITT AUSTRIA GmbH**  
A-2000 STOCKERAU  
Ernst Vogel-Straße 2  
Tel. (+43) 02266 604  
Fax (+43) 02266 65311  
e-mail: info.ittaustria@itt.com  
http://www.ittaustria.com

**FRANCE**  
**LOWARA FRANCE S.A.S.**  
BP 57311  
37073 Tours Cedex 2  
Tel. (+33) 02 47 88 17 17  
Fax (+33) 02 47 88 17 00  
e-mail: lowarafr.info@itt.com  
http://www.lowara.fr

**GERMANY**  
**ITT LOWARA DEUTSCHLAND GmbH**  
Biebigheimer Straße 12  
D-63762 Grobostheim  
Tel. (+49) 0 60 26 9 43 - 0  
Fax (+49) 0 60 26 9 43 - 2 10  
e-mail: lowarade.info@itt.com  
http://www.lowara.de

**IRELAND**  
**ITT IRELAND**  
50 Broomhill Close  
Airton Road  
Tallaght  
DUBLIN 24  
Tel. (+353) 01 4524444  
Fax (+353) 01 4524795  
e-mail: lowara.ireland@itt.com -  
http://www.lowara.ie

**NEDERLAND**  
**LOWARA NEDERLAND B.V.**  
Zandweistraat 22  
4181 CG Waardenburg  
Tel. (+31) 0418 65 50 60  
Fax (+31) 0418 65 50 61  
e-mail: sales.nl@itt.com  
http://www.lowara.nl

**POLAND**  
**LOWARA VOGEL POLSKA Sp. z o.o.**  
PL 57-100 Strzelin  
ul. Kazimierza Wielkiego 5  
Tel. (+48) 071 769 3900 - Fax (+48) 071 769 3909  
e-mail: info.lowarapl@itt.com -  
http://www.lowara-voegel.pl

**PORTUGAL**  
**ITT PORTUGAL, Lda**  
Praçeta da Castanheira, 38  
4475-019 Barca  
Tel. (+351) 22 9478550  
Fax (+351) 22 9478570  
e-mail: info.pt@itt.com  
http://www.itt.pt

**RUSSIA**  
**LOWARA RUSSIA**  
Kalanchevskaya st. 11 b.2, off. 334  
107078 Moscow  
Tel. (+7) 495 631 55 15  
Fax (+7) 495 631 59 72  
info.lowararu@itt.com - www.lowara.ru

**UK**  
**LOWARA UK LTD.**  
Millwey Rise, Industrial Estate  
Axminster - Devon EX13 5HU UK  
Tel. (+44) 01297 630200  
Fax (+44) 01297 630270  
e-mail: lowaraukenquiries@itt.com  
http://www.lowara.co.uk

For additional addresses, please visit  
[www.lowara.com](http://www.lowara.com)

cod. 191003871 W 12/09

*Lowara reserves the right to make modifications  
without prior notice.*